

# AlphaGate MKII & Sesame 2

Bunnings Entry & Exit Gate Solution  
Installation Manual

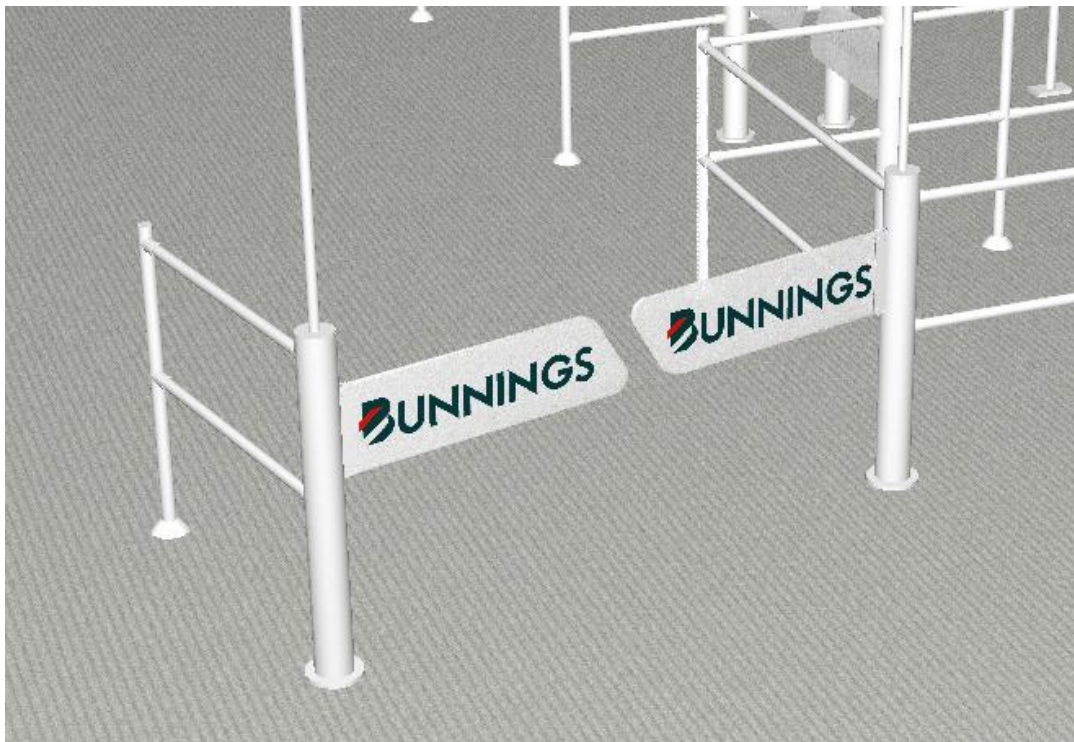

## Version Control

Version	Date	Comments	Issued by
1.0	13/01/2026	<ul style="list-style-type: none"> <li>• First version</li> </ul>	Jonathan Gunnarsson
2.0	25/03/2026	<ul style="list-style-type: none"> <li>• Updated version based on findings from first installation</li> </ul>	Jonathan Gunnarsson
2.1	27/03/2026	<ul style="list-style-type: none"> <li>• Timing and dip switch changed</li> </ul>	Jonathan Gunnarsson
2.2	06/05/2026	<ul style="list-style-type: none"> <li>• Full document: Updated the manual to align with the new Radford documentation visual standard.</li> <li>• Chapter 5.3, Page 14: Updated the preferred installation method for the power cable to enter from the bottom of the gate instead of the top.</li> <li>• Chapter 5.4, Page 16: Added Entry Gate labelling option for the isolation switch.</li> <li>• Chapter 7, Page 21: Updated wording to include the PEC and reflector on the first pair of an entry gate when a second pair is installed.</li> <li>• Chapter 8.3, Page 25: Removed the child safety sensor installation requirement as requested by Bunnings.</li> <li>• Chapter 8.4, Page 26: Updated the image of the DIP switches on the ScanMaster board for improved clarity.</li> <li>• Chapter 8.5, Page 27: Updated the approach radar triggering distance by adding a minimum distance of 1.5 m where required to avoid triggering from bypassing traffic.</li> <li>• Chapter 8.5, Page 27: Clarified that approach radars are only required on the first pair of an entry gate when two saloon gates are installed.</li> <li>• Chapter 10, Pages 30–38: Updated receiver and remote instructions to align with the new Bunnings standard.</li> <li>• Chapter 12, Page 41: Added clearer guidance for installation of the push button near the main register at the service desk, ensuring it is within easy reach of staff.</li> <li>• Chapter 13, Pages 42–47: Updated the installation and sign off checklist to provide more detail and reflect the changes listed above.</li> </ul>	Jonathan Gunnarsson
2.3	21/05/2026	<ul style="list-style-type: none"> <li>• Chapter 2.3, Page 8: Updated the network connectivity diagram to display the Store tracker instead of the VM version.</li> <li>• Chapter 8.2, Page 23: Updated the SECURE/SCO potentiometer setting from 16 seconds to 6 seconds for both the Main Register Exit Gate and Service Desk Exit Gate.</li> <li>• Chapter 9, Pages 27 to 29: Added ScanMaster upright installation instructions directly into the manual instead of referring to a separate document.</li> <li>• Chapter 13, pages 43 to 48: Refined all steps in the installation &amp; commissioning sign off checklist for all gate types.</li> <li>• Chapter 14, page 49: Added a store sign off form.</li> </ul>	Jonathan Gunnarsson



## Table of Contents

1.	General information .....	4
1.1.	AlphaGate MKII & Sesame 2 solution introduction .....	4
1.2.	Contact Information .....	5
1.3.	Declaration .....	5
1.4.	Disclaimer list .....	6
1.5.	AlphaGate MKII Technical data .....	6
2.	Sesame sensor/spider installation .....	7
2.1.	Install drop down poles for Sesame sensors .....	7
2.2.	Sensor Installation Troubleshooting .....	7
2.3.	Install data cables to Sesame sensors .....	8
2.4.	Install the Spider Device .....	8
3.	Internet connectivity kit installation .....	9
3.1.	Internet connectivity kit Content .....	9
3.2.	Setup Internet connectivity kit .....	9
4.	Dropper pole installation .....	10
5.	AlphaGate MKII Entry & Exit installation .....	12
5.1.	AlphaGate MKII Dimensions .....	12
5.2.	Gate pole installation .....	13
5.3.	Connecting power to gate .....	14
5.4.	AlphaGate MKII isolation switch installation .....	16
5.5.	Gate arm installation .....	17
6.	Connection of synchronization cable .....	19
7.	Install PEC and Reflector on the Gates .....	21
8.	Setup AlphaGate MKII settings .....	22
8.1.	Setup Main PCB DIP switch settings .....	22
8.2.	Setup Potentiometer settings .....	23
8.3.	Configuration of ScanMaster 2.0 SD card .....	24
8.4.	DIP-switch settings ScanMaster .....	25
8.5.	Approach Radar Installation .....	26
9.	Installation of ScanMaster Upright .....	27
10.	Remote Control Installation .....	31
10.1.	Remote Control Functions .....	32
10.2.	Wire the Receiver to AlphaGate Control Board .....	33
10.3.	Mount the remote receiver .....	37
10.4.	Set the pairing DIP Switches & Pair Remotes .....	38
10.5.	Set the receiver channels to Latching or Momentary .....	40
11.	Check the gate timing using the ScanMaster board .....	41
12.	Gate override push button for Exit gates at Service desk .....	42
13.	Installation & commissioning sign-off checklist .....	43
14.	Store sign off .....	49



# 1. General information

## 1.1. AlphaGate MKII & Sesame 2 solution introduction

The ITAB Sesame 2/Alpha system is a unique system fully developed by ITAB AB Sweden that incorporates patented software.

Sesame 2 is designed to identify the customer who has fully completed payment for the purchase of goods at the checkout POS terminal.

This payment confirmation was achieved via a series of overhead camera sensors (loaded with Itab IP software) profiling the people standing next to the payment terminal at the same moment their payment has been validated through the same checkout payment terminal.

Upon validation by the store POS payment terminal a signal is instantaneously sent to a device (usually installed at the back end of the store) known as a storetracker (also loaded with Itab IP software) and validates a customer using the overhead mounted camera sensors.

At the physically controlled exit point, a set of AlphaGates are installed to create a physical barrier to non-paid customers and only opening for the paid and validated customer as they approach a pre-set distance to the AlphaGate.

After the paid customer passes through the gates, they return to their normally closed position thereafter awaiting the next paid customer to approach.

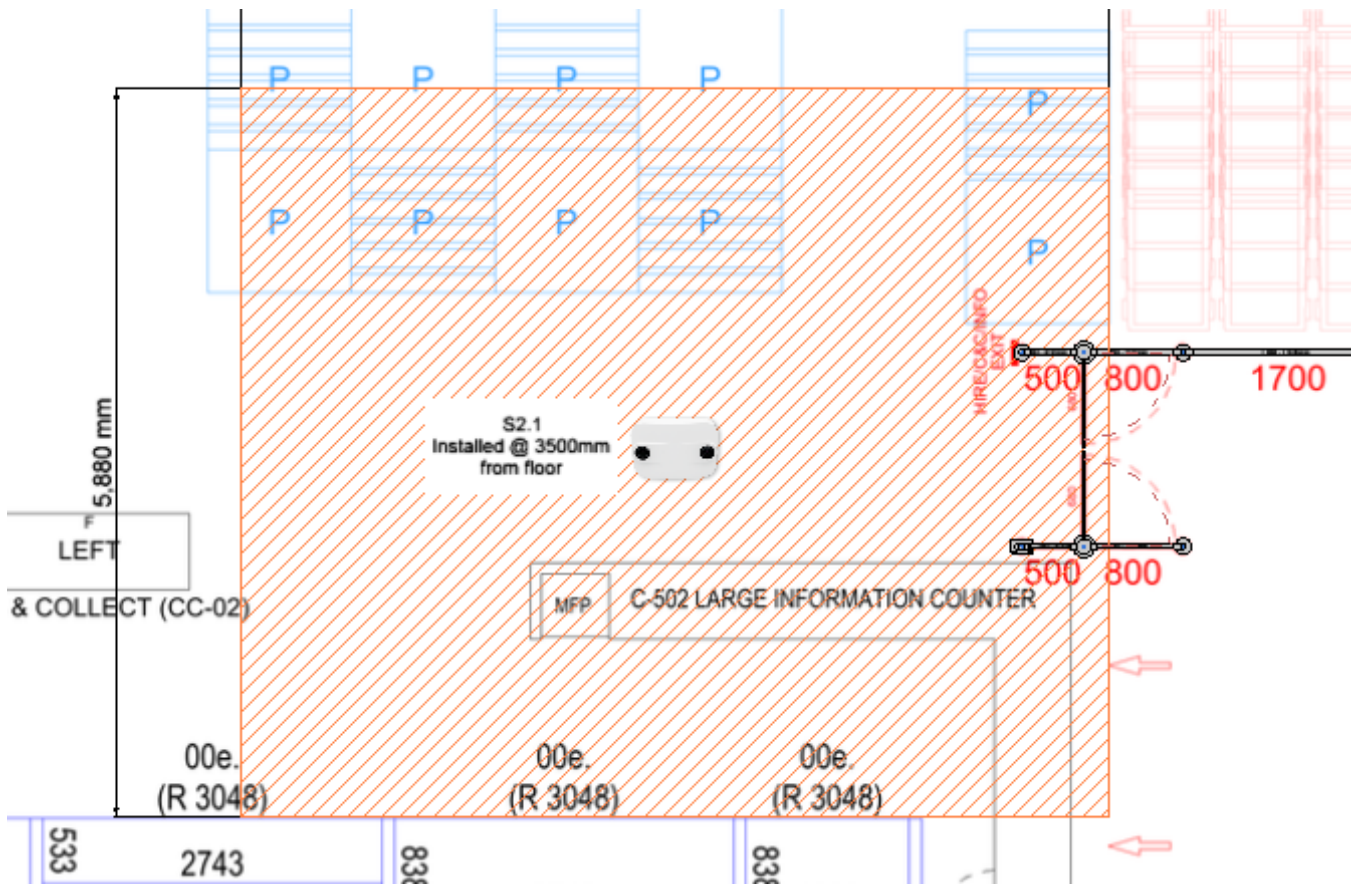

## 1.2. Contact Information

**Shipping & Postal address:** Unit 6/5-7 Malta St Fairfield East  
**Web address:** <https://www.radfordretail.com/>  
**Software support:** [support@radfordretail.com](mailto:support@radfordretail.com)  
**Service:** [service@radfordretail.com](mailto:service@radfordretail.com)  
**Knowledge base:** <https://radfordretail.zendesk.com/hc/en-au>

## 1.3. Declaration

ITAB Shop Products AB automatic Alphagate MKII is possible to force to open manually when an evacuation situation occurs.

When the gate is activated, it is possible to force the gate with a force bigger than 30Nm (adjustable between 20-70Nm).

When the gate is inactivated it is possible to force the gate with a force less than 20Nm.

The panic breakout mechanism is designed to withstand more than 20 000 panic breakouts.



### Declaration of Conformity

**Manufacturer of Entrance/Exit System:** ITAB Shop Products AB  
Box 9054  
SE-550 09 Jönköping SWEDEN

**Description:** Electronic Entrance/Exit System  
ALPHAGATE MKII

The electronic entrance/exit system has been developed, designed and finished in accordance with the provisions of the following Directives:

Machinery Directive 2006/42/EG  
Low Voltage Directive 2014/35/EU  
Directive on electromagnetic compatibility (EMC) 2014/30/EU

Applied Norms for testing:  
EN 61000-6-2:2005  
EN 61000-4-2, -3, -4, -5, -6, -11  
EN 61000-6-3:2007  
EN 60335-1:2012 + A1:2019 + A2:2019 + A11:2014 + A12:2017 + A13:2017 + A14:2019 + AC1:2014 + A13R1:2019  
AS/NZS 60335.1:2011 (Incorporating Amendment Nos 1, 2, 3, 4 and 5)  
EN 60335-2-103:2015

**ITAB Shop Products AB**  
Box 9054  
SE-55009 JÖNKÖPING  
SWEDEN

Jönköping, 2020-12-09

  
Jan Andersson  
Managing Director



## 1.4. Disclaimer list

This automatic gate is intended for installation by a professional installer. Installation by other than professional installers could result in a non-conforming automatic gate and hazardous situations.

**The Alphagate must be assembled and used below 4000 meters above sea level.**

**Warranty void if the automatic gate is not installed by a professional installer.**

**Warranty void if product label is removed or not readable.**

**Connecion of 220-240V~ (or selected 110V~) to the gate and connection of plug-in connector to power cable is only allowed to be done by electricians or by ITAB authorized installer with sufficient knowledge.**

## 1.5. AlphaGate MKII Technical data

### Gate

- Voltage: 220–240 V~ or selected 110 V~
- Frequency: 50/60 Hz
- Current:
  - Max 0.5 A at 220–240 V~
  - Standby: 0.2 A
  - Operation: 0.3 A
  - Max 1 A at 110 V~
  - Standby: 0.4 A
  - Operation: 0.5 A
- Temperature: 0–35 °C
- IP rating: IP20
- Installation: Indoor use only
- Weight: 27 kg

### Motor

- Voltage: 24 VDC
- Power rating: 20 W
- Rated current: 0.9 A

### PEC (Photo Electric Cell)

- Voltage: 10–30 VDC
- Output: NPN
- Switching capacity: 100 mA
- Power input: 25 mA

### Radar Movement Detector

- Voltage: 12–24 VDC
- Max power: 60 mA
- Transmission frequency: 24.175 GHz
- Transmission power: < 5 mW/cm<sup>2</sup>
- Output: NPN

### Additional Power Supply (ScanMaster)

- AC input: 230 V~
- DC output: 12 V
- Rated power: 15.6 W
- Current range: 0–1.3



## 2. Sesame sensor/spider installation

### 2.1. Install drop down poles for Sesame sensors

Install drop down poles and mount camera sensors, precisely as located from provided floorplan.

**Important notes on installing Sesame sensors onto the drop-down poles:**

- a) Must be installed as per matching ID as each sensor will have its own IP address and location above the floor – check with to ensure the correct Sesame sensor match the overhead floor location.
- b) Must be installed at a specific height.
- c) Must be Installed Level.
- d) Must be installed rigidly to prevent movement.
- e) Must be installed as per individual store drawing – check with builder as dimensions (floor location & height from floor) are critical and will vary from site to site.
- f) Must be kept free from dust and grease.
- g) Sensors cannot be installed above 3.5 m height unless anything else communicated.

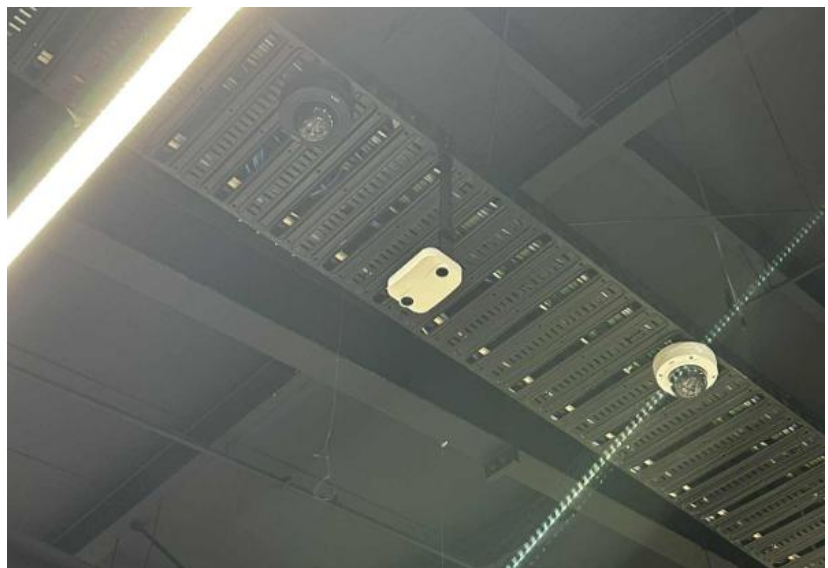

### 2.2. Sensor Installation Troubleshooting

To prevent sensor coverage issues or sensors failing to come online, it's important to follow the process below. This ensures coverage is properly checked and all sensors are verified on the network. The activity should be completed on the first night to allow time to resolve any potential issues.

**Process:**

- a) Unpack and ping all sensors before installation.
- b) Install sensors in the ceiling according to the plan.
- c) Ping sensors again after installation.
- d) Review with Radford the following morning to confirm coverage and verify that all sensors are 100% level and in position.



### 2.3. Install data cables to Sesame sensors

Install data cables as plug & play cables from each Sesame sensor and spider (if required) to the PoE switch that came with the shipment.

**Note: If more than nine Xovis sensors are used, an additional device (spider) will also have to be connected to the network. See drawing below showing a typical schematic of the sesame 2 hardware including the virtual store racker.**

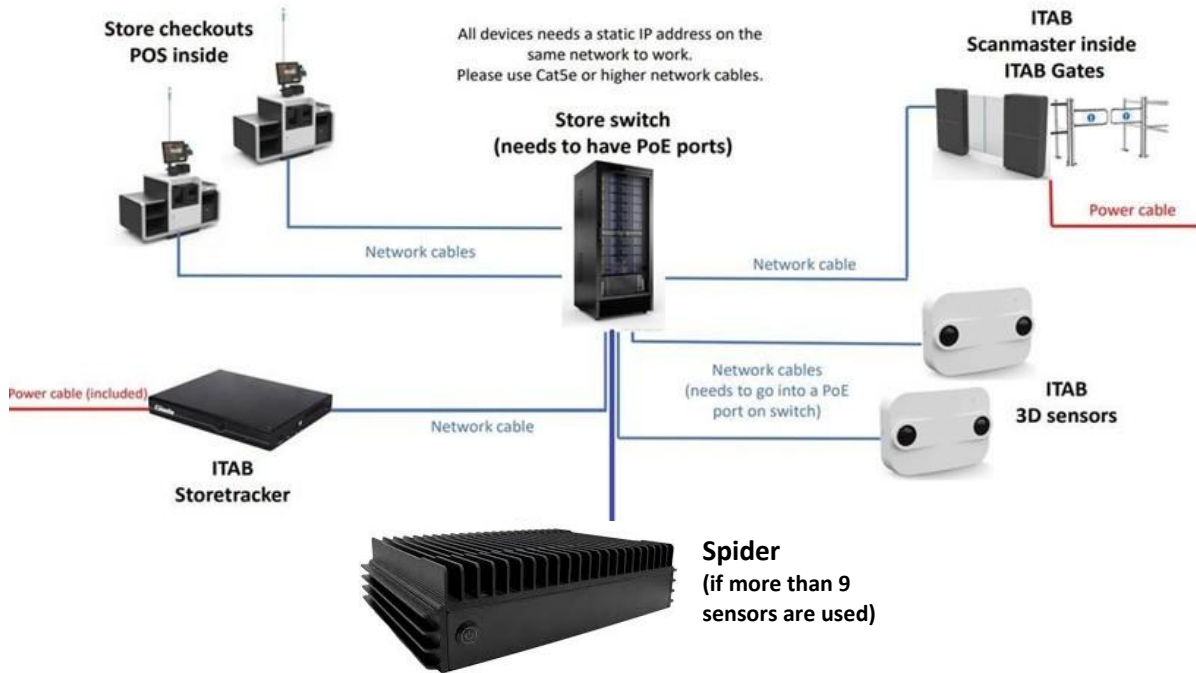

**Note: Store checkouts and POS systems are already connected to the store switch, and it is not necessary/required to run additional patch leads to the checkouts.**

### 2.4. Install the Spider Device

The Spider devices are to be placed in the comms cabinet (see site manager for cabinet number) and be plugged into a 240v power outlet using the power cables provided.

Connect the Spider to the switch using a cat5e or higher network cable. Plug one end of network cable into the network port on the spider. See IPTracker for port number.

**Please note that a spider is only needed if more than 9 sensors are being used in the same zone**



### 3. Internet connectivity kit installation

The Sesame 2 solution requires internet connectivity for initial setup, software updates and remote support. If the Sesame 2 devices and the gates cannot be connected to the store network for different reasons an Internet connectivity kit is required to provide internet access.

#### 3.1. Internet connectivity kit Content

The kit will always include the following:

- 1 x Network modem
- 1 x PoE switch 16 ports
- 5 x Cat6 network cables

#### 3.2. Setup Internet connectivity kit

All devices part of the kit should be stored in a sufficiently enclosed network cabinet at the service desk area in the store. All data cables from the Sesame sensors, the exit AlphaGates and ScanMaster upright barcode scanners must be routed to this network cabinet. When all devices are plugged in and connected to power the system should be remotely accessible remotely without any further actions.

Example connection of a store with one store tracker, one alpha gate exit gate, one ScanMaster upright barcode scanner and one sensor.

**Note: Use the included Cat6 network cables to connect the Network modem and store tracker to the PoE switch. The data cables for the gates and Sesame sensors will have to be provided by the installer.**

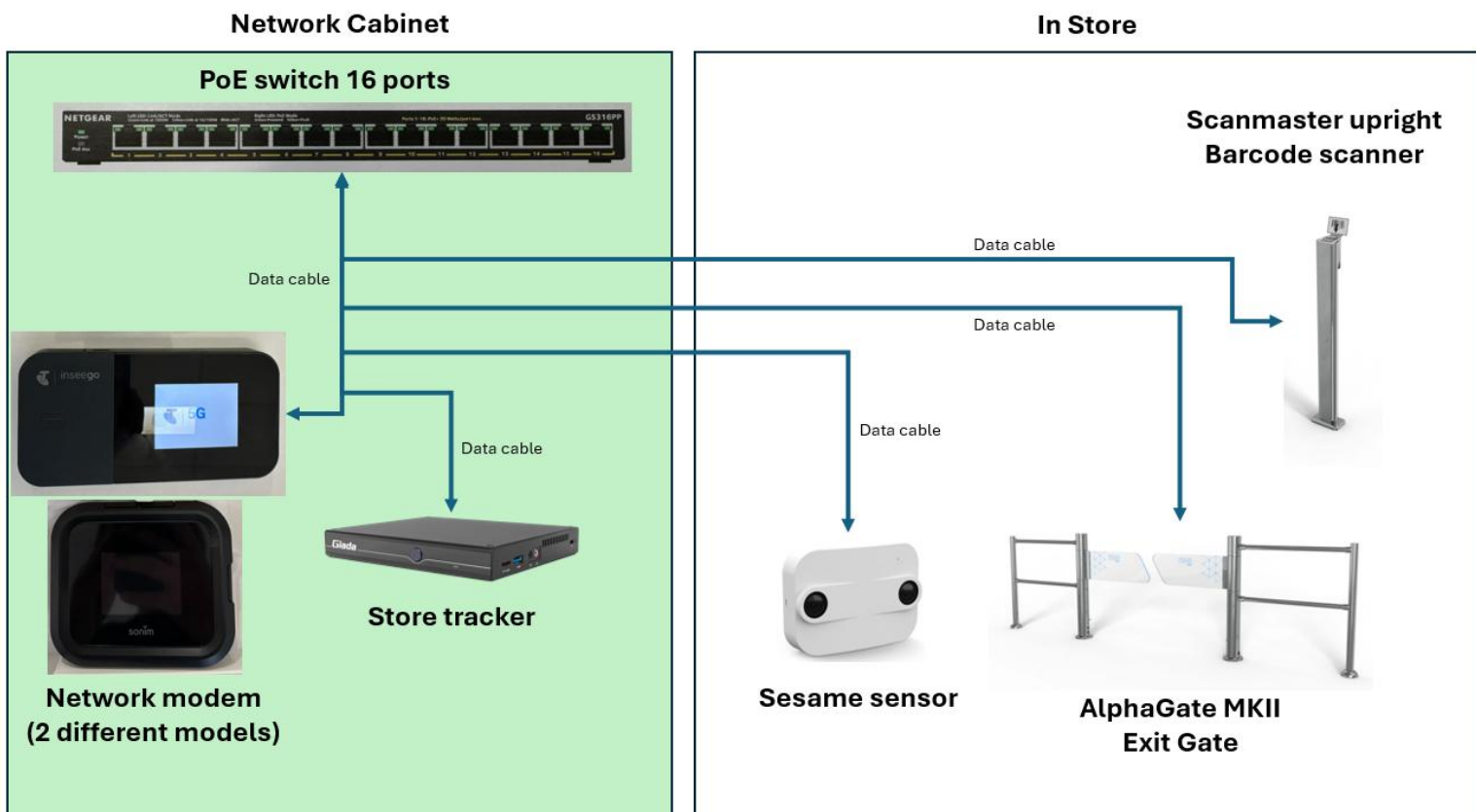

## 4. Dropper pole installation

Since Bunnings requires all cabling to be chased overhead it is necessary to install dropper poles to every gate pole in the store unless anything else has been agreed.

The dropper poles is needed to run the power-, data-, synchronisation- and fire trip cables to the gates.

The dropper poles are supplied by the installer.

**Note: Bunnings got special instructions on how to install the dropper poles to the ceiling.**

**Make sure you read through this manual before installing the dropper poles.**

To be able to run the cables into the gate easily there will be new top lids with an opening supplied with the delivery to run the cables into the gate.

The opening is 25 Ø.

Variant	Surface	Quality
23608-01	Chrome	Ni/Cr 20µm
23608-04	Powder coating, S&P	Salt&Pepper

2	2	Set screw M8x8	077031
1	1	Top cover threaded hole c/w clamp	23608-81
Item	Qty.	Title	
Designer	UH	Approved	Where no tolerance is specified: SS-ISO 2768-m
			Scale 1 : 1
		Top cover threaded hole c/w clamp	Replaces
		Alphagate MKII	Date 2009-11-24
			Dwg.no. 23608



Below is an example of how an installation could look like with chrome dropper poles installed.



## 5. AlphaGate MKII Entry & Exit installation

This chapter will go through how to install an AlphaGate MKII hardware in its position on the floorplan. The hardware installation will be the same for both the entry and exit gates. After the AlphaGate poles have been installed in the ground, the commissioning of the settings will be different between the entry and exit gates.

### 5.1. AlphaGate MKII Dimensions

Since the AlphaGate comes in many configurations, below will only cover Bunnings standard configurations.

- Motorised Column
  - 120 mm
  - 180 mm incl. foot cover
- Height 1 120 mm
- Gate arm
  - 28 mm
  - Distance between spigots = 250 mm
  - 1 100 mm (cut to length)

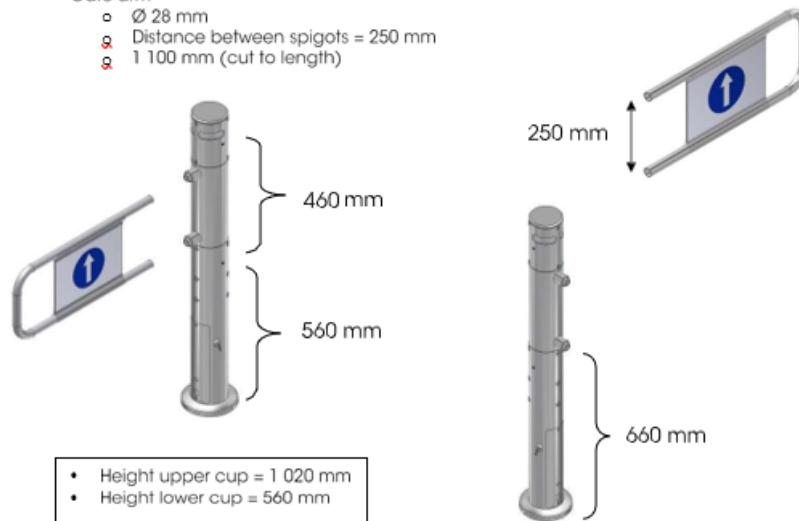

**Note: Make sure to follow the below measurements when installing the entry and exit gates since the plan may be slightly different in some cases.**

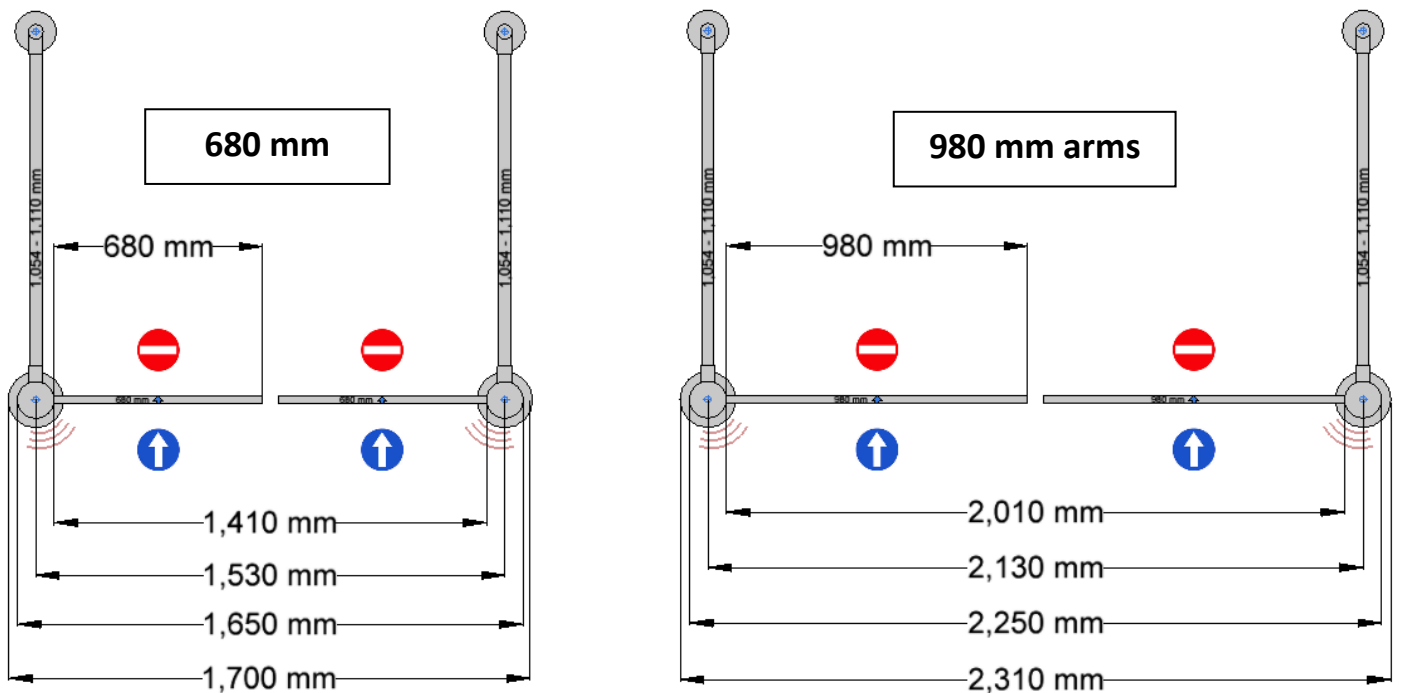

## 5.2. Gate pole installation

- Since Bunnings isn't chasing any cables in the floor and all cables is chased through the overhead dropper poles you can start with fixing the gate to the floor before running the cables.
- Confirm bollard and post measurements with the site manager before drilling.
- Mark drilling points and floor chase lines for main bollards only once measurements are confirmed. Mark drilling points using the automatic gate mounting plate. Use the mounting plate to align the main bollards against each other.
- Uprights and rails will be installed after the main bollards have been installed.
- Remove main bollards and complete floor chasing for power and synchronisation cabling.
- Repair any loose fixings with chemical anchors if concrete is inadequate.
- Ensure all cables pass through the base plate in a safe way according to standards before fixing the gate to the floor. Make sure that metal shavings are removed.
- Use suitable fixings penetrating at least 75 mm into the floor, appropriate to the floor material.
- Cut rails as per floorplan. Mark drilling holes for Uprights. Make sure to align the uprights with the main bollards.

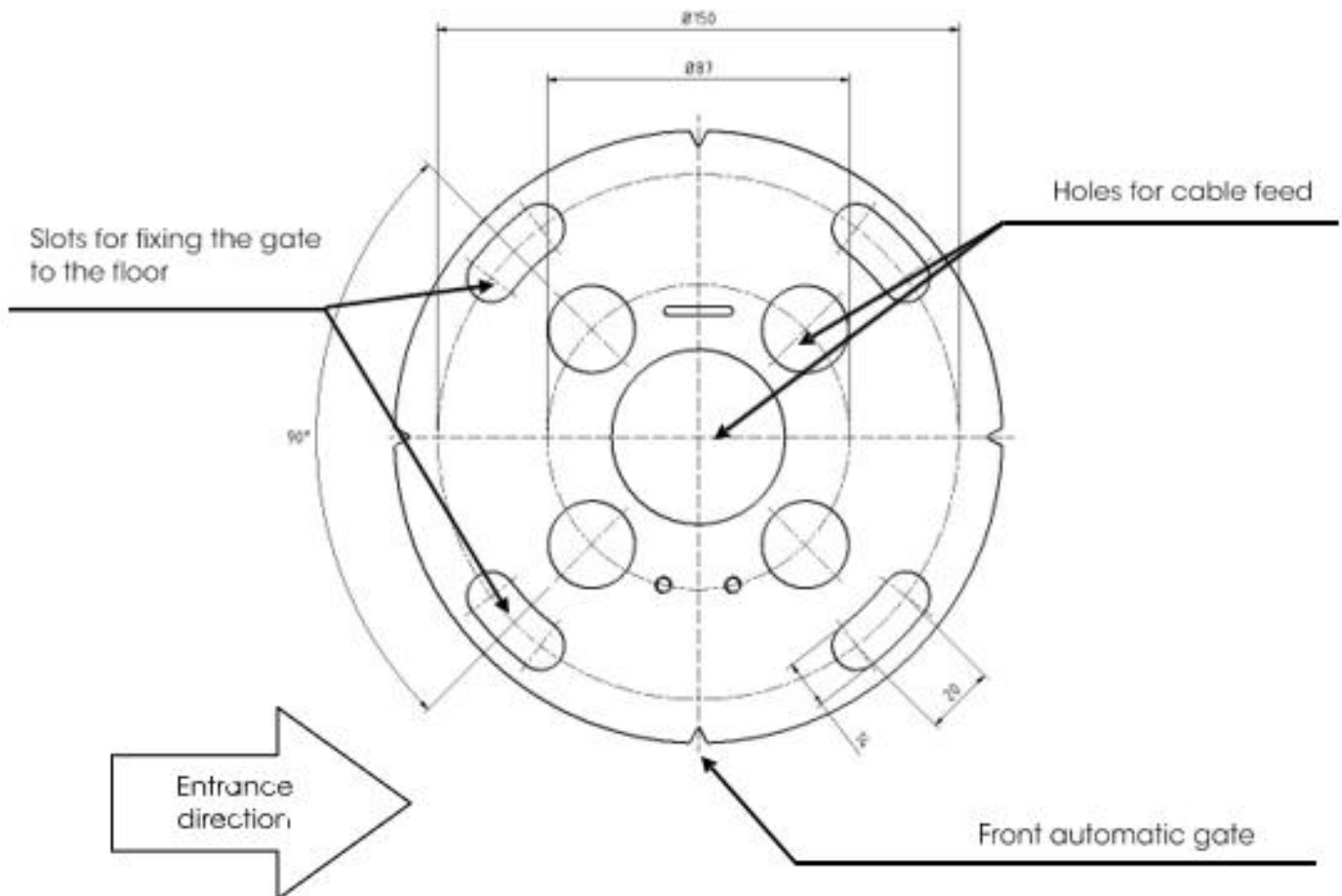

**Before fixing the gate permanently to the floor the gate must be powered up to ensure a correct 0 degree initial position. Note: Make sure the approach delay is not set to minimum when testing the gate to enable gate to fully open 90°.**



### 5.3. Connecting power to gate

Both AlphaGate poles require a 220-240V power supply chase connected to them. You can connect the power supply both at the top and bottom of the gate.

**Note: It is preferable to install the power to the gate at the bottom of the gate, if possible, to make it easier to service since the dropper poles will block access to the top once installed.**

It's also possible to supply power from one gate to another. See picture for further explanation.

- The power feeding to the system must have a max. 10A fuse. The
- Maximum cable area for incoming mains terminal = 2.5mm<sup>2</sup>
- Always make sure that the cables can't be pinched or be damaged by sharp edges.



**Mains connectors are dangerous when power is connected to the AlphaGates. Always disconnect the power to the mains terminal before conducting any work on the gate.**

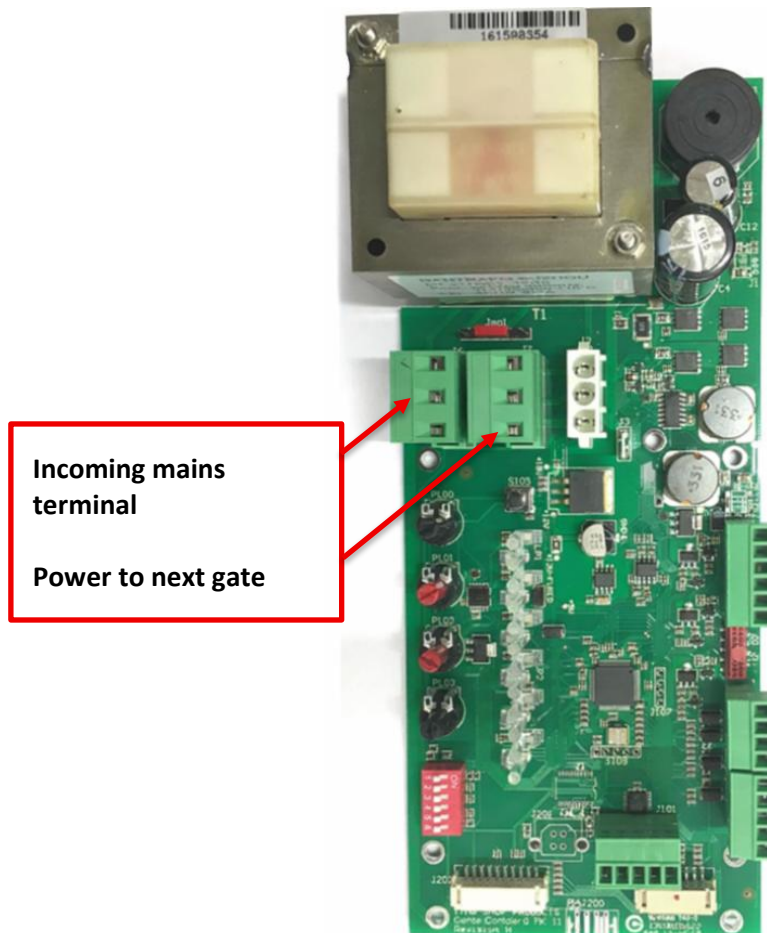



## 5.4. AlphaGate MKII isolation switch installation

The isolation switch provides a dedicated means to disconnect power to the gates for servicing, maintenance, or emergency shutdown. All gates installed need to be connected to an isolation switch.

### Recommendations

#### Switch type:

- 10A minimum grey isolator, *Clipsal IP56 Series 56SW110-GY* (or equivalent).

#### Labelling:

- Must be clearly labelled “EXIT GATE POWER.” Or “ENTRY GATE POWER.”

#### Ingress protection:

- Minimum IP56 rating for moisture and dust protection.

#### Circuit connection:

- Connect to the UPS power circuit that supplies the exit gate.
- Ensure total gate load (120 W max per gate) does not overload the circuit.
- Install a dedicated UPS circuit if necessary.

### Mounting location & details

- Mount the isolator directly above the black metal wall duct serving the exit gate.
- Duct specification: 2-channel black metal duct, 150 × 50 mm (ECD or Cableway).
- The isolator should be easily accessible to store staff and service personnel.
- No service poles are to be used in the exit gate area.

### Installation notes

- All wiring must comply with AS/NZS 3000 electrical standards.
- Coordinate location and connection with the electrical contractor responsible for gate power routing.
- Verify isolator function as part of commissioning and handover testing.



### 5.5. Gate arm installation

1. Remove the 6 screws holding Glass Bracket **A**.
2. Remove Glass Bracket A and Rubber Pad **B**.
3. Attach the Glass Arm. Make sure Rubber Pad **C** is properly in place between the Glass Bracket **D** and the Glass.
4. Push the 2 plastic sleeves through the corresponding holes in the Glass and make sure there is no contact between the glass surface and the Glass Bracket bolts.
5. Attach the Rubber Pad B and the Glass Bracket A and tighten the 6 Glass Bracket screws.

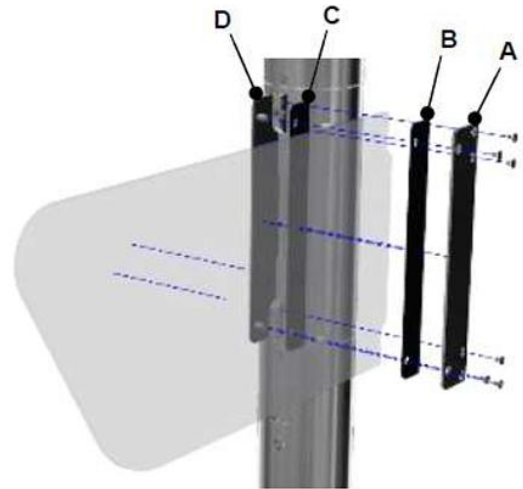

It is very important to make sure that ALL components are fitted to the Glass arm bracket correctly before placing the glass arm into the bracket. If not, breakage is likely to occur.



Ensure no cables associated with the LED-stripe are not damaged before fitting and during fitting of the glass arms.



Gently tighten glass arm bracket screws until the plastic spacer flattens up tight to the glass arm.



Make sure to check that the Rubber Pad and plastic spacers are not overlapping each other and that all components are aligned correctly before firmly tightening all glass arm fixings in place.



Glass arms to be installed nose down/nose up according to the floorplan provided.

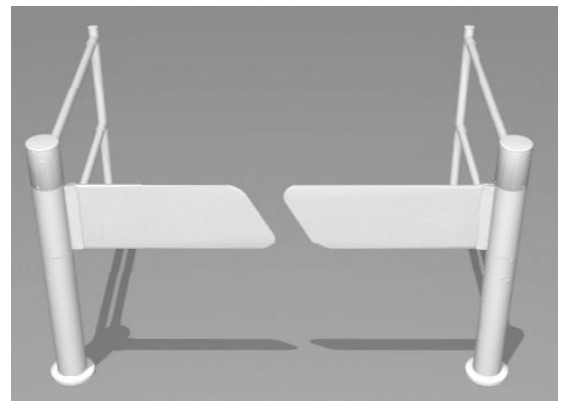

### Adjust closed position

If the gate arms closed position are not aligned and needs to be adjusted, loosen the screw that fixing the Coulisse. Move the Coulisse a little bit to the left or to the right depending on how the gate arm needs to be adjusted. Move carefully, small movements are enough to adjust the gate arm several centimeters. When the gate arm is satisfactory adjusted, fasten the screw again. To be able to do this adjustment, the power needs to be switched on to the gate. Make sure no sensors are connected during this setup (or turn off the power to the motor by turning the key switch). If not, gate movements when adjusting can break the Coulisse.

Move to the right      ➡ gate arm moves to the left.  
Move to the left      ➡ gate arm moves to the right.



Make sure that no sensors are connected during this setup.



## 6. Connection of synchronization cable

To be able to get the gates to work as a pair, a synchronization cable (GateCOM cable supplied with the delivery) needs to be connected between the gates.

When the gates are connected, LED diode SALOON GATE will have a steady green light on both Main PCB: s inside the gate poles.

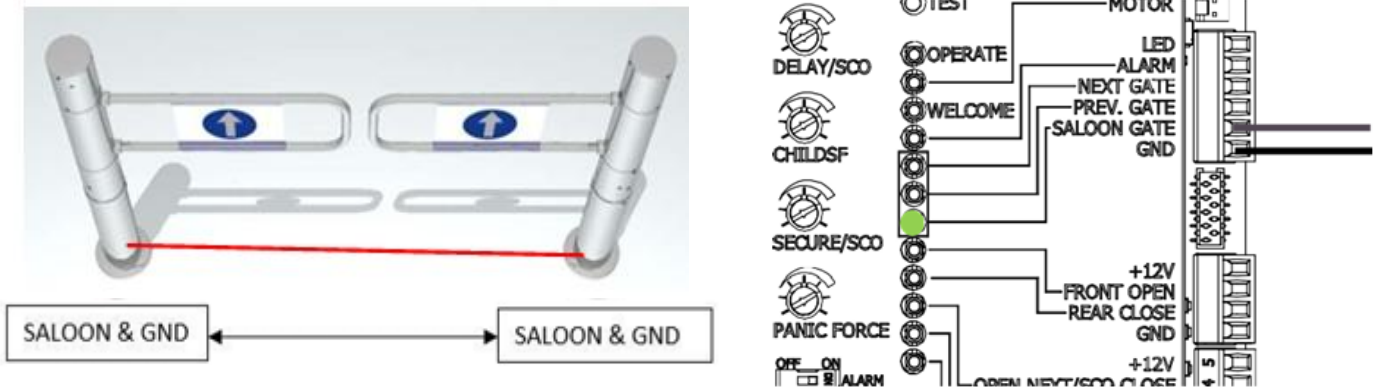

There are 2 configurations part of the Bunnings format. If it's a single saloon gate, you would only require one sync cable to be wired in between the 2 gate poles. See I - configuration below.

The second configuration is sometimes used at the entrance when there is 2 saloon gates part of the gate family. When you got 2 saloon gates you would also need to wire the sync cable between the 2 gate pairs and 2 cables between the pairs as in the C – configuration below.

**Note: Since Bunnings require all cables to run overhead, the sync cables will have to be chased through the dropper poles.**

Exit & Entry gates:

I- Configuration



Entry gates only:

C- Configuration

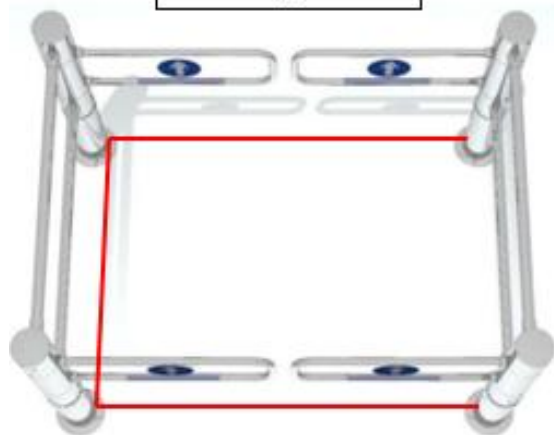

**Synchronization cable routing example when connecting 2 saloon gates together.**

Below is an illustration of the GateCOM cable route through a gate family.

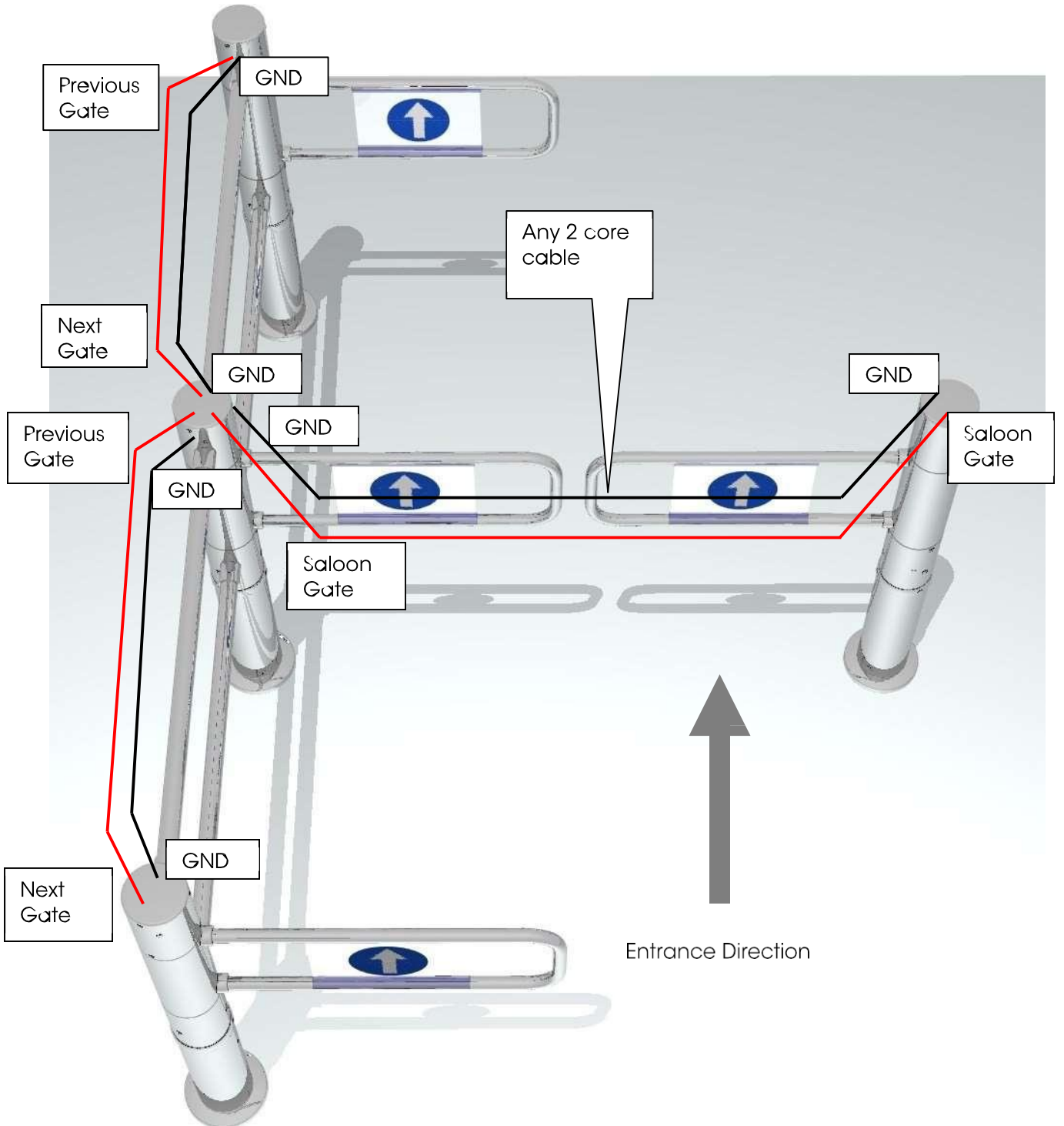

## 7. Install PEC and Reflector on the Gates

**Note: All Exit gates installed in the store will have to have the PEC line installed for the potentiometer timings to function as expected.**

**Note: All Entry gates where there is a second gate pair installed you will need to install the PEC and reflector on the first pair to trigger the second pair to open. The first pair will be triggered by the approach radars.**

Install the PEC sensor as per the image below. (Should be wired in to the board at the bottom of the gate). The reflector should be in the gate pole on the other side.

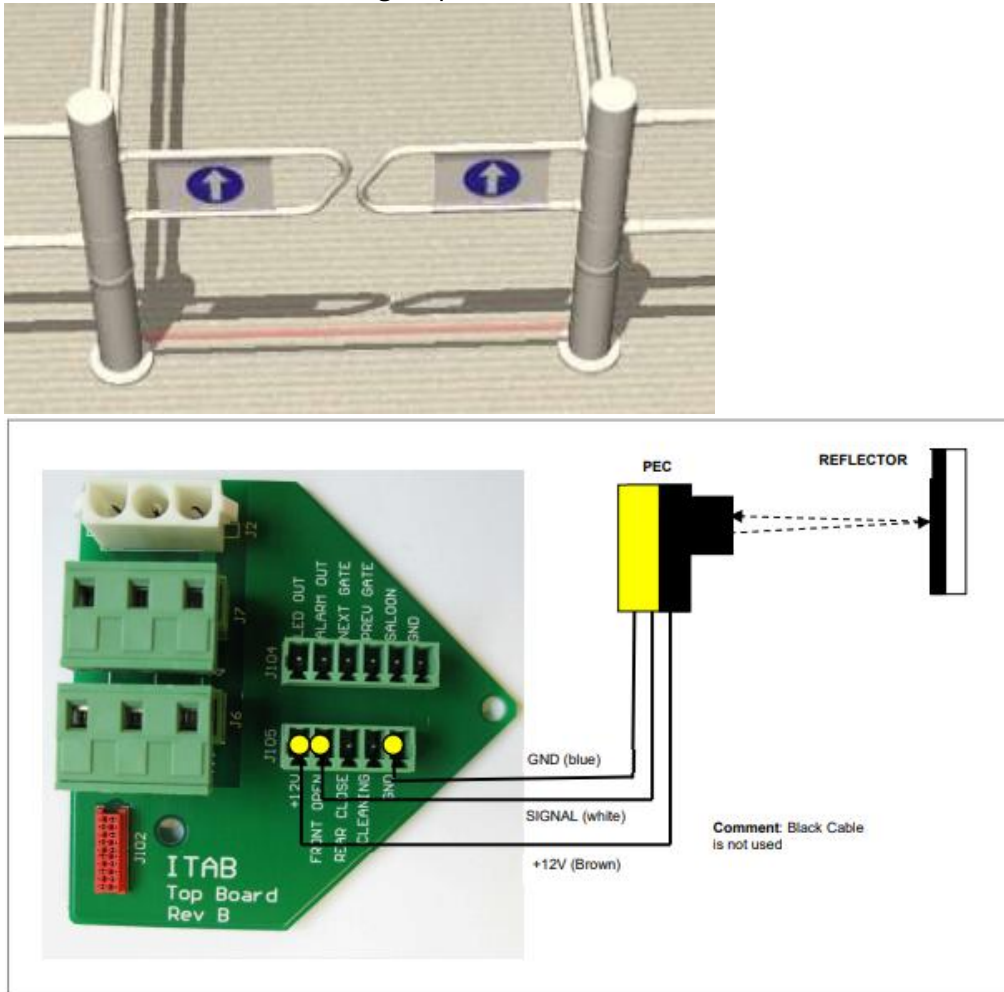

### Adjusting the PEC

- Connect the PEC to power it up. Now the GREEN led light should be on.
- Trim the vertical and horizontal angle of the PEC until the YELLOW led light is on. NOTE: the yellow led must show a steady light, flickering light is not optimal.



## 8. Setup AlphaGate MKII settings

### 8.1. Setup Main PCB DIP switch settings

Set up dip switch functions on each Main PCB.

Both the left and the right gates should have the same settings on all dip switches except on number 2 (left/right).

Upon entering the store, the gate on your left side is considered a left-hand gate.

The gate on your right is considered right-hand gate.

#### ENTRY GATE & EXPRESS EXIT GATE SETTINGS:

##### Dip switches standard settings:

- 1 = **Right** position (Alarm on)
- 2 = **Left** or **right** position (Depending on the gate)
- 3 = **Right** position (Alarming for 10s)
- 4 = **Left** position (Entry gate)
- 5 = **Left** position (Entry gate)
- 6 = **Right** position (Slow speed on gate arm)

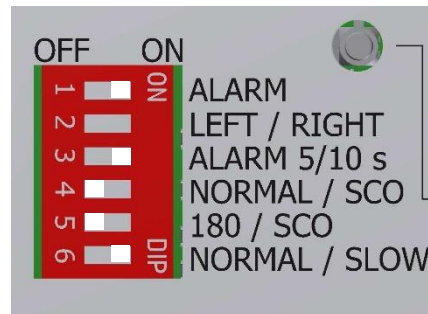

#### MAIN REGISTER EXIT GATE & SERVICE DESK EXIT GATE SETTINGS (With Sesame):

##### Dip switches standard settings:

- 1 = **Right** position (Alarm on)
- 2 = **Left** or **right** position (Depending on the gate)
- 3 = **Right** position (Alarming for 10s)
- 4 = **Right** position (Exit gate)
- 5 = **Right** position (Exit gate)
- 6 = **Right** position (Slow speed on gate arm)







## 8.2. Setup Potentiometer settings

Set up Potentiometer settings on each Main PCB. The right gate as you walk through the gate should always be the master, and the left gate should always be the slave. To active master and slave function, potentiometer 1 (DELAY/SCO) and 3 (SECURE/SCO) must be set to maximum (clockwise) on the left gate.





**Note: To obtain master and slave function to be operational, the gate family must be connected with GateCOM (SALOON).**

0% = Potentiometer turned all the way anticlockwise.  
 100% = Potentiometer turned all the way clockwise.

### **ENTRY GATE & EXPRESS EXIT GATE SETTINGS:**

	<b>LEFT GATE</b>	<b>RIGHT GATE</b>
	Maximum (100%)	(20%) to obtain 4s delay.
	Minimum (0%)	Minimum. (0%)
	Maximum (100%)	Minimum. (0%)
	Halfway (50%)	Halfway (50%)

### **MAIN REGISTER EXIT GATE & SERVICE DESK EXIT GATE SETTINGS (With Sesame):**

	<b>LEFT GATE</b>	<b>RIGHT GATE</b>
	Maximum (100%)	Halfway (50%) to obtain 4s delay.
	Minimum (0%)	Minimum. (0%)
	Maximum (100%)	One fifth of the way (~20%) to obtain 6s delay.
	Halfway (50%)	Halfway (50%)



### 8.3. Configuration of ScanMaster 2.0 SD card

**Note: A ScanMaster is only required for exit gates with Sesame and Exit gates with a ScanMaster upright barcode scanner.**

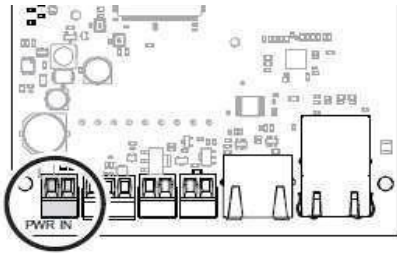

- 1 Disconnect the 12V power supply cable to cut the power.

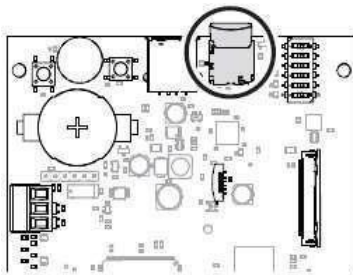

- 2 Put the Micro SD card for specific gate to the ScanMaster board.  
**Note: PLEASE CHECK THAT THE SDCARD IS THE CORRECT CARD FOR THE CORRECT GATE.**  
 Check against floor plan and IT Tracker.

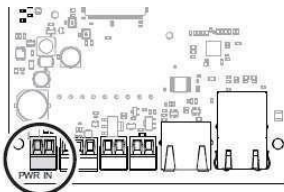

- 3 Connect the 12V power supply cable.



- 4 The ScanMaster board will initialize over approximately 90 seconds. Once complete, the LED indicators should display as follows:
  - LED 1 - *Blinking green*: Indicates normal operation.
  - LED 5 - *Single orange blink*: Triggers once when a POS message is received
  - LED 10 - *Solid red*: Indicates fault or error state.



### 8.4. DIP-switch settings ScanMaster

**Note:** This is only required for exit gates with Sesame and Exit gates with a ScanMaster upright barcode scanner.

The settings below should be set the same on all ScanMaster boards used in the store.

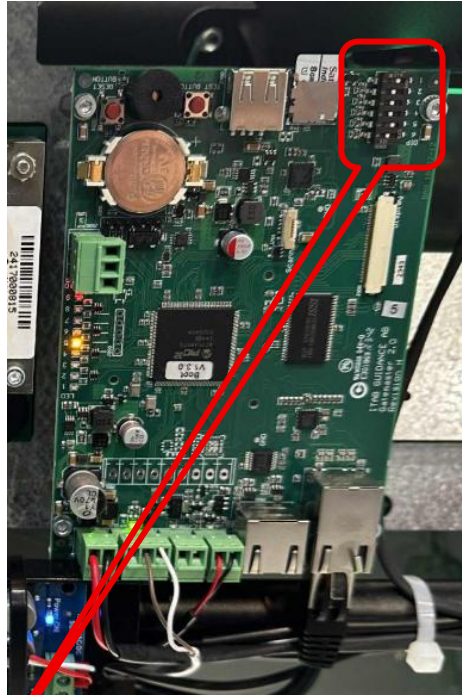

ScanMaster DIP-switches

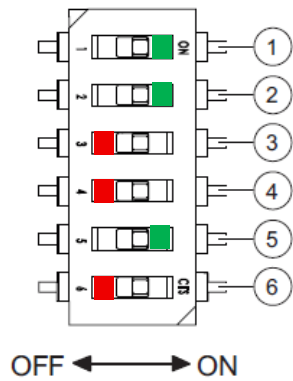

- 1. Buzzer on/off = **Right (ON)**
- 2. Ethernet required = **Right (ON)**
- 3. Service mode = **Left (OFF)**
- 4. Service IP (192.168.20.200) = **Left (OFF)**
- 5. GateCOM required = **Right (ON)**
- 6. Display on/off = **Left (OFF)**



## 8.5. Approach Radar Installation

**Note: An approach radar is required to be installed on the first pair of an entry gate configuration and the exit gate with the ScanMaster upright barcode scanner. The Sesame exit gates should NOT have any radars installed.**

Install the radar in the top of the AlphaGate pole facing the direction of where customers will enter through the gate.

It's possible to adjust the sensitivity of the radars, by adjusting the small potentiometer. See below pictures.

Standard recommendation is to position the radars, so they detect customers approaching the gates at a distance of **2 meters**. Depending on the store layout, the detection range may need to be reduced, with a minimum distance of **1.5 meters** if required. Test one sensor at a time to ensure both units cover the same detection area. The installer is responsible for confirming and signing off on the final detection distance in-store.

**Note: Please make sure all gates on approach radars isn't triggering open by bypassing traffic.**

Fig. 9

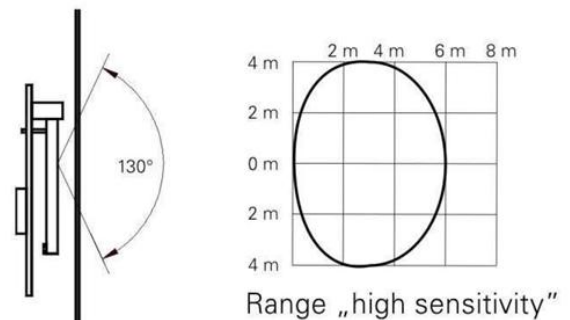
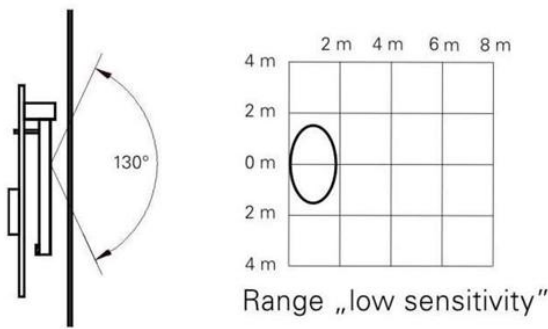
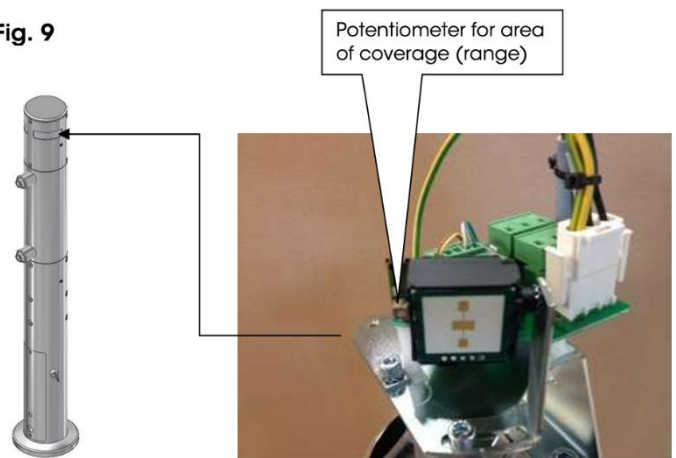

How to wire in the radar to the top board of a gate:

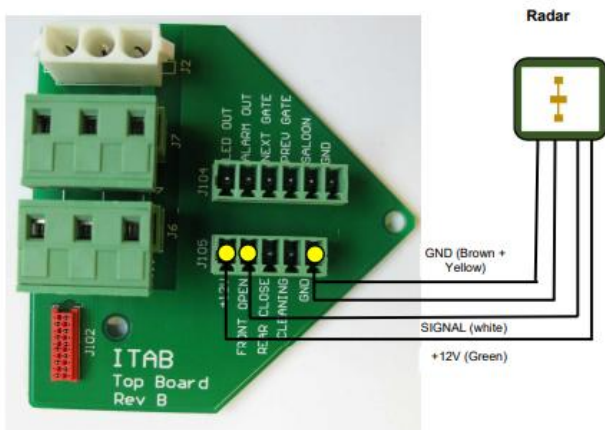

## 9. Installation of ScanMaster Upright

To install the ScanMaster upright, please use the manual following the ScanMaster Upright kit or the instructions below.

**Note: do not forget to install the SD-card in this ScanMaster and to wire the data cable from the ScanMaster inside and not from the actual Exit gate.**

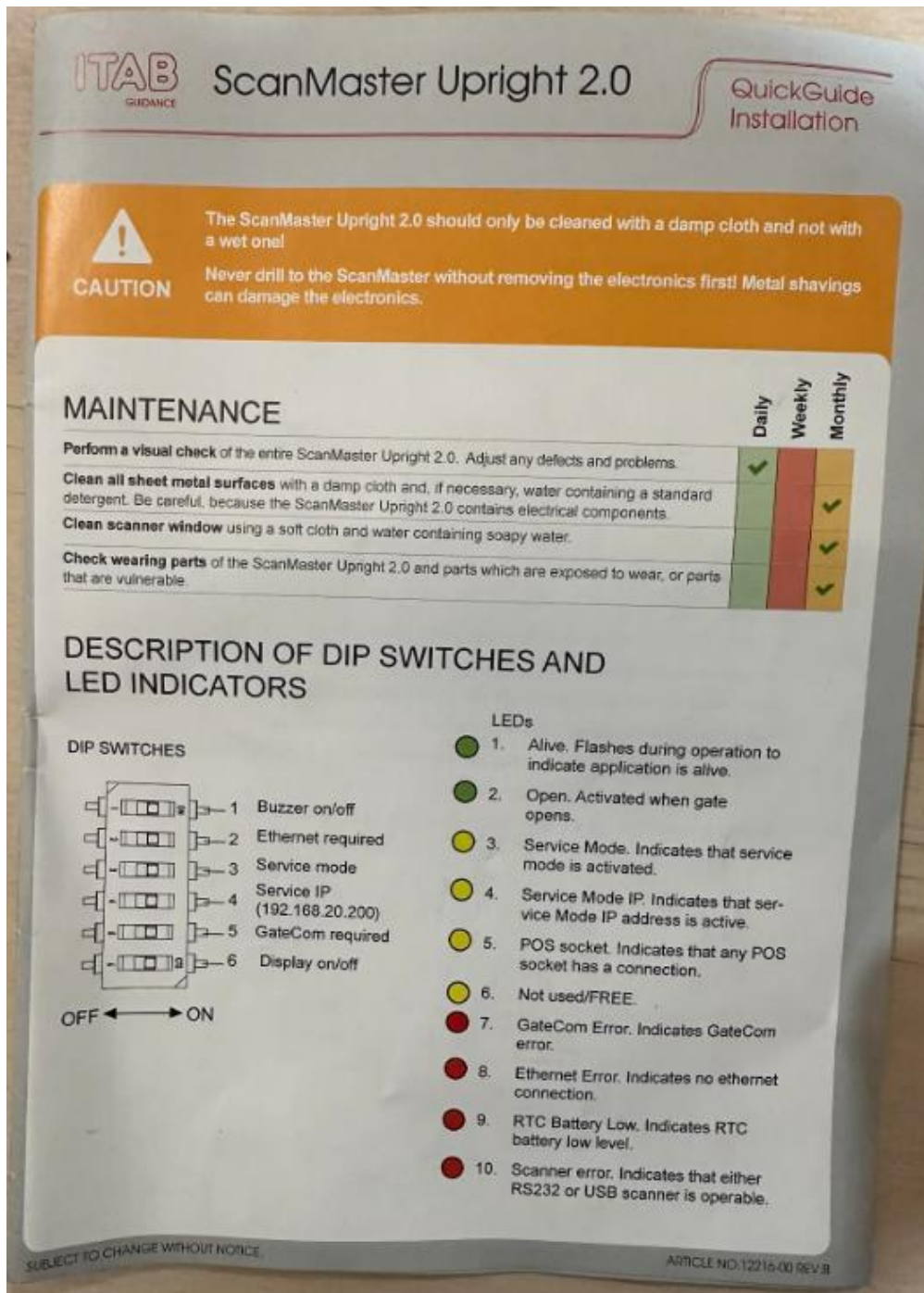

**1** Place the ScanMaster Upright 2.0 at a suitable distance from the gate, recommended distance is 500-1000mm from the gate, see figure below.

**2** Mark the drilling points through the mounting location for ScanMaster Upright 2.0, then mount the post with four appropriate fasteners.

(If the cabling should be installed via the floor ensure that all cables are passed through the base plate before the post is mounted to the floor).

**3** Alt 1: Remove the Scanner window (1) and Cable cover (2).  
Remove the Backplate with reset button and 12v cable. (3).  
Route cables (4) from the gate through the rail and scanner housing to the GateMaster 2.0.  
Connect cables to GateMaster 2.0, refer to step 5 on the following page.  
Mount the Backplate (5) using two screws. Make sure that the cables are not clamped.  
Mount the Cable cover using two screws (6).  
Mount the Scanner window (7) and Information plate (8) using two screws.



**4** Alt 2: Remove the Backplate (1).  
 Route the cabling (2) from the floor up through the post.  
 Connect cables to GateMaster 2.0, refer to step 5.  
 Mount the Backplate (1) using two screws.  
 Mount the Information plate (3) using two screws.

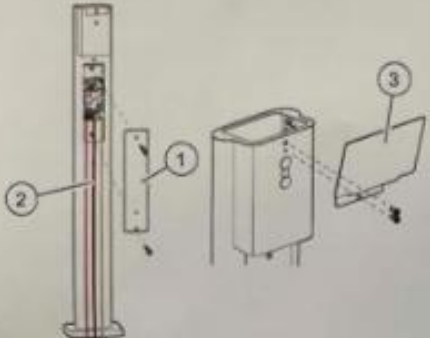

**5** Connect the cables at the GateMaster 2.0:  
 1 Ethernet shielded CAT5 or higher (optional if POS connected).  
 2 GateCOM.  
 3 Power in (12V DC) from the gate via reset button.

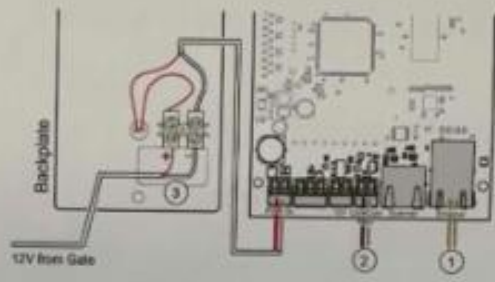

**6** GateMaster 2.0 connection to the Gate.

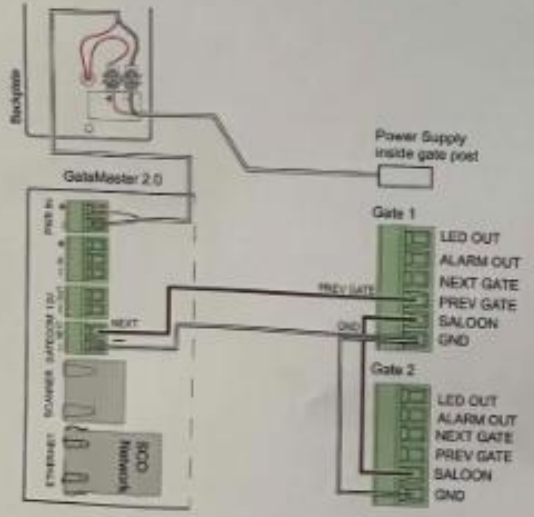

**! DANGER OF LIFE!**

**WARNING** During maintenance, disconnect the power supply to the ScanMaster Upright 2.0! There is always external power supply.

Make the ScanMaster Upright 2.0 powerless, by pulling out all power strip plugs.

**Before contacting Helpdesk**

Please do these steps before contacting Helpdesk

**1. Read**  
the Quick Guide Installation

**2. Read**  
section 8 Troubleshooting in the Operator and Technical Manual

**3. Note**  
article, situation, serial number

**4. Contact**  
Helpdesk

## TROUBLESHOOTING

Check that all cables are correctly connected. The LED for power supply shines green when the power supply is connected, see figure below (1).

Press the TEST BUTTON to see that the gate opens. If not, check the GateCOM connection.

If the scanner does not start up within one minute when connecting the power supply, press the RESET BUTTON at the lid or GateMaster 2.0 to restart. The scanner has two LEDs that will shine with white light when the scanner is running correctly.

If the LED-strip inside the Scanner housing flashes red check the following:

1. Cables are correctly connected, refer to 5.2.3 connect cables.
2. Micro SD card is correctly connected. The buzzer alarms if the micro SD card is missing or not correctly connected.
3. DIP switches are correctly configured, refer to 5.4 DIP switches
4. Press the RESET BUTTON at the lid or GateMaster 2.0 to restart. The scanner has two LEDs that will shine with white light when the scanner is running correctly. If the problem persists, contact helpdesk.

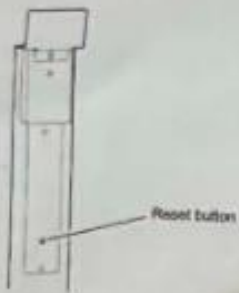

Reset button

Test button

Reset button

Micro SD card

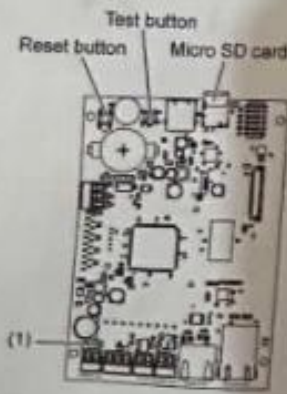



## 10. Remote Control Installation

The following instructions will explain how to install a remote receiver inside an AlphaGate and how to set up the remote's functions if there are multiple gates in the store controlled by the remote control.

**Note: The Generation 3 receiver does not include wiring.**

**The installer will need to supply the necessary cables.**

**To connect the receiver to the gate, you will need three 30 cm long 2-core wire cables.**

**Elsema Remote Receiver:**

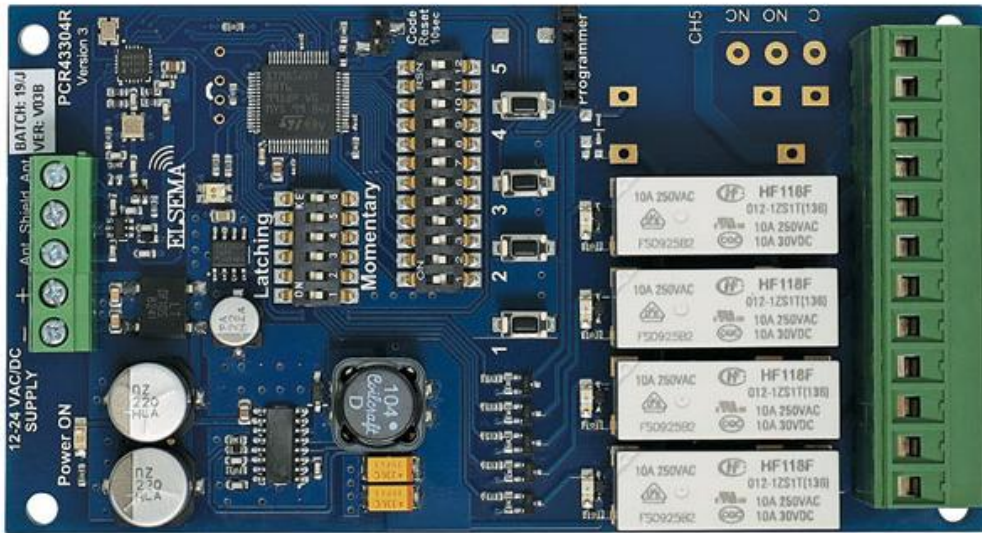

## 10.1. Remote Control Functions

Bunnings will use two types of remotes to control their gates.

A red remote with four buttons will be provided to the Leader on Duty, giving access to all available functions.

A blue remote with two buttons will be used by door greeters and checkout staff, allowing access to functions of button one and two only.

Standard qty delivered for each Bunnings store is 6 x red remotes and 3 x blue remotes.

**Button 1** – activate 'Auto Close' on Exit gate at Main Checkout area.

**Button 2** – activate 'Cleaning Mode (permanent open mode)' on the Entry gate.

**Button 3** – no function.

**Button 4** – activate 'Cleaning Mode (permanent open mode)' on all gates in the store.



**Leader on Duty remote functions:**

**Button 1** – activate 'Auto Close' on Exit gate at Main Checkout area.

**Button 2** – activate 'Cleaning Mode' on the Entry gate.

**Button 3** – no function.

**Button 4** – activate 'Cleaning Mode' on all gates in the store.



**Door Greeter/Checkout staff remote functions:**







**Button 1** – activate 'Auto Close' on Exit gate at Main Checkout area.

**Button 2** – activate 'Cleaning Mode' on the Entry gate.



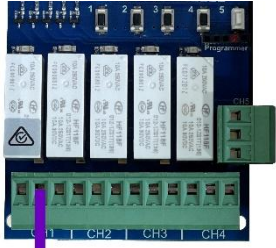



## 10.2. Wire the Receiver to AlphaGate Control Board

### Main Register Exit Gate

Receiver	AlphaGate Control Board
<p>Supply +</p> 	<p>12V</p>
<p>Supply -</p> 	<p>Ground</p>
<p>Ch1 NO</p> 	<p>Front Open</p>
<p>Ch1 C</p> 	<p>Ground</p>
<p>Ch4 NO</p> 	<p>Cleaning</p>
<p>Ch4 C</p> 	<p>Ground</p>







Express Exit Gate with ScanMaster Upright

Receiver	AlphaGate Control Board
<p>Supply +</p> 	<p>12V</p>
<p>Supply -</p> 	<p>Ground</p>
<p>Ch4 NO</p> 	<p>Cleaning</p>
<p>Ch4 C</p> 	<p>Ground</p>



Exit Gate at Service desk (if applicable)

Receiver	AlphaGate Control Board
<p>Supply +</p> 	<p>12V</p>
<p>Supply -</p> 	<p>Ground</p>
<p>Ch4 NO</p> 	<p>Cleaning</p>
<p>Ch4 C</p> 	<p>Ground</p>



Entry Gate

Receiver	AlphaGate Control Board
<p>Supply +</p> 	<p>12V</p>
<p>Supply -</p> 	<p>Ground</p>
<p>Ch2 NO</p> 	<p>Cleaning</p>
<p>Ch2 C</p> 	<p>Ground</p>
<p>Ch4 NO</p> 	<p>Cleaning</p>
<p>Ch4 C</p> 	<p>Ground</p>



### 10.3. Mount the remote receiver

Install the remote receiver at the bottom of the right-hand side AlphaGate pole. A receiver must be installed for every gate pair/family.

Place the remote receiver according to the picture in the right-hand side gate. Use a cable tie to fit it.



### 10.4. Set the pairing DIP Switches & Pair Remotes

1. On all receivers, set switches 1-10 (outlined in green below) to match the postcode of the store using the examples in the table below.

As an example, if the store has a number 8 in the postcode, set DIP switch 8 to the ON/Up position and ignore any zeros in the postcode. If the postcode has the same number more than once like 8888 only switch 8 must be set to ON/Up and rest will be OFF/Down.

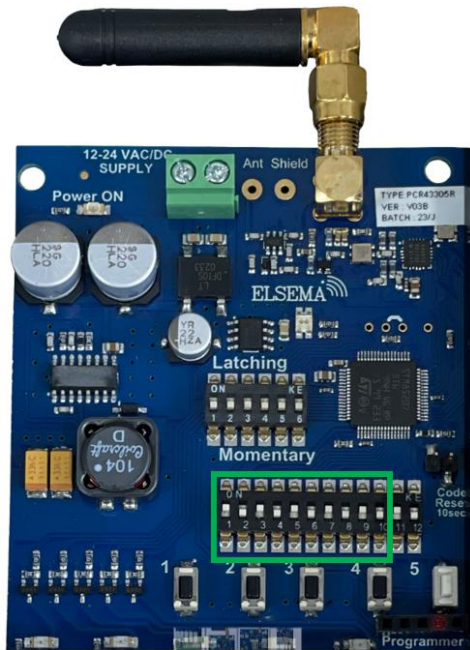

Store postcode	DIP Switches 1-10																				
0043	<table border="1"> <tr><td>ON</td><td></td><td></td><td></td><td></td><td></td><td></td><td></td><td></td><td>DIP</td></tr> <tr><td>1</td><td>2</td><td>3</td><td>4</td><td>5</td><td>6</td><td>7</td><td>8</td><td>9</td><td>10</td></tr> </table>	ON									DIP	1	2	3	4	5	6	7	8	9	10
ON									DIP												
1	2	3	4	5	6	7	8	9	10												
0333	<table border="1"> <tr><td>ON</td><td></td><td></td><td></td><td></td><td></td><td></td><td></td><td></td><td>DIP</td></tr> <tr><td>1</td><td>2</td><td>3</td><td>4</td><td>5</td><td>6</td><td>7</td><td>8</td><td>9</td><td>10</td></tr> </table>	ON									DIP	1	2	3	4	5	6	7	8	9	10
ON									DIP												
1	2	3	4	5	6	7	8	9	10												
3571	<table border="1"> <tr><td>ON</td><td></td><td></td><td></td><td></td><td></td><td></td><td></td><td></td><td>DIP</td></tr> <tr><td>1</td><td>2</td><td>3</td><td>4</td><td>5</td><td>6</td><td>7</td><td>8</td><td>9</td><td>10</td></tr> </table>	ON									DIP	1	2	3	4	5	6	7	8	9	10
ON									DIP												
1	2	3	4	5	6	7	8	9	10												
3344	<table border="1"> <tr><td>ON</td><td></td><td></td><td></td><td></td><td></td><td></td><td></td><td></td><td>DIP</td></tr> <tr><td>1</td><td>2</td><td>3</td><td>4</td><td>5</td><td>6</td><td>7</td><td>8</td><td>9</td><td>10</td></tr> </table>	ON									DIP	1	2	3	4	5	6	7	8	9	10
ON									DIP												
1	2	3	4	5	6	7	8	9	10												
1364	<table border="1"> <tr><td>ON</td><td></td><td></td><td></td><td></td><td></td><td></td><td></td><td></td><td>DIP</td></tr> <tr><td>1</td><td>2</td><td>3</td><td>4</td><td>5</td><td>6</td><td>7</td><td>8</td><td>9</td><td>10</td></tr> </table>	ON									DIP	1	2	3	4	5	6	7	8	9	10
ON									DIP												
1	2	3	4	5	6	7	8	9	10												

2. The table below explains Dip switch 11 and 12. The first receiver should always have Off/Off. If you the store has two receivers. The first should have Off/Off and the second should have On/Off. Follow the table for all the different set ups.

	Receivers Dip Switch 11	Receiver Dip Switch 12
Receiver 1	Off	Off
Receiver 2	On	Off
Receiver 3	Off	On
Receiver 4	On	On

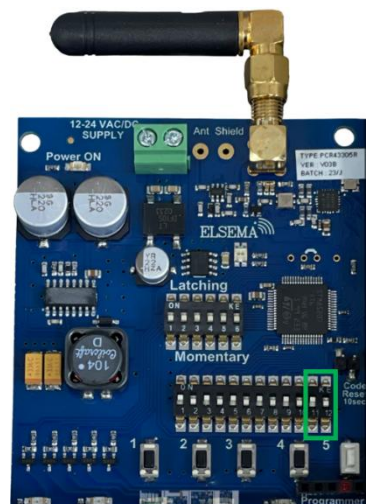

- 3. Set DIP switches 1-10 in the remote exactly the same as the receiver. Dip switch 11 and 12 should always be Off/Off.



- 4. Insert the battery and test the functions.

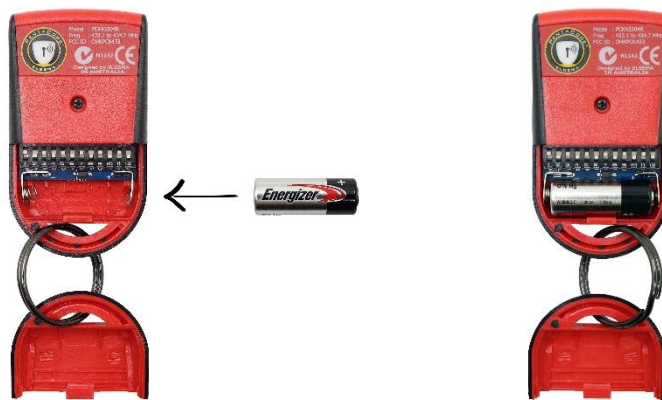

### 10.5. Set the receiver channels to Latching or Momentary

To configure if the incoming signal on each channel should latch or trigger the channel momentarily you will have to set the DIP switches to the following.

1. Change Mode Selection on the 6 DIP switches (outlined in red below). Change the DIP switches on each receiver as shown below:

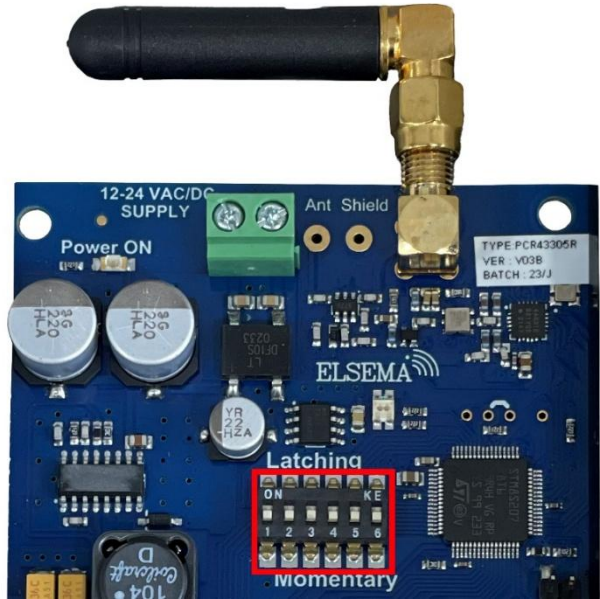

**Main Register Exit Gate**

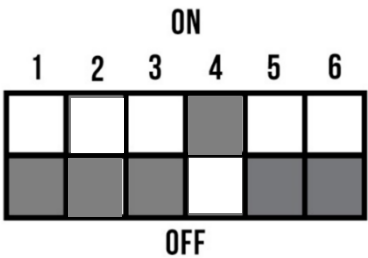

**Exit Gate at Service desk (If applicable)**

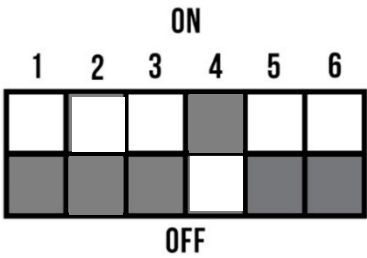

**Express Exit Gate with ScanMaster Upright**

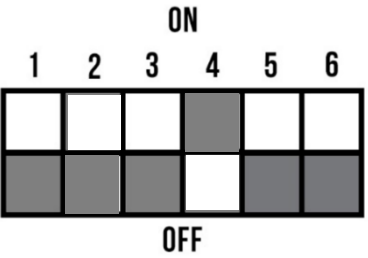

**Entry Gate**

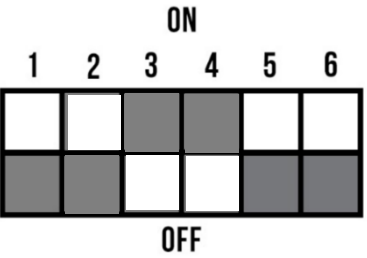

## 11. Check the gate timing using the ScanMaster board

**Note:** This is only working for exit gates with Sesame and Exit gates with a ScanMaster upright barcode scanner.

Use the test button on the ScanMaster to trigger the gate. This will send an open gate signal to help check the timing of the gate. Please note that this will only trigger the gate and start the Secure timer until the PEC sensor is broken.

**Hint:** Use your hand to break the PEC beam at the bottom of the gate to start the DELAY timer on an Exit gate.

The Exit gate should remain open for 16 seconds if PEC beam isn't broken.

When PEC beam has been broken, the gate should remain open for 4seconds before closing.

If timing isn't right, go back to chapter 8.2 and adjust potentiometer settings as per the instructions.

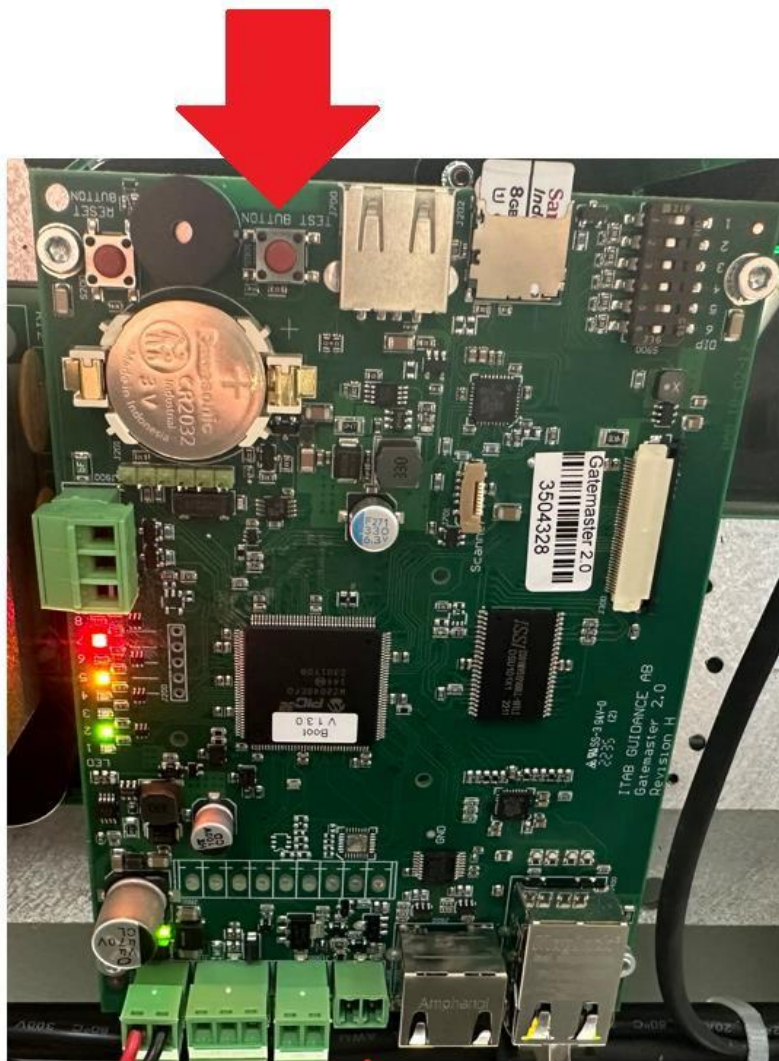

## 12. Gate override push button for Exit gates at Service desk

**Note: Push button is only required for the service desk gate. If there is no service desk gate there is no need to install the push button.**

**Please make sure the push button is installed nearby the register where customers will be served as standard at the service desk to avoid the staff having to move to the push button to let anyone out.**

In stores where there is an exit gate at the service desk it is mandatory to install a gate override push button behind the counter.

This allows staff to manually trigger the auto-close function when needed.

Below is a basic wiring diagram illustrating how to connect the push button to the gate PCB.

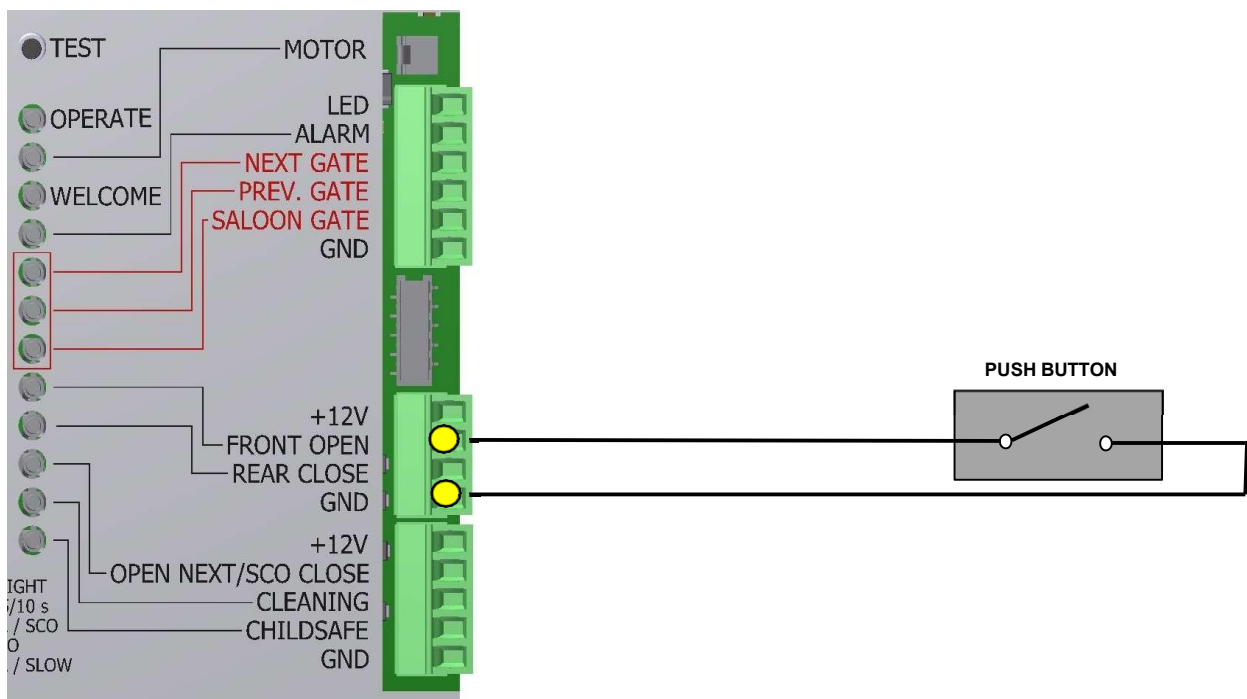

Bunnings push button:



### 13. Installation & commissioning sign-off checklist

The installation team is responsible for completing the below sign off checklists for all equipment installed in the store. Please complete one table each per gate area you have installed.

The records should be consolidated and sent to [support@radfordretail.com](mailto:support@radfordretail.com) as records of a successfully completed installation.

<b>General Checklist</b>	<b>✓</b>	<b>✗</b>	
Installer to check that gates are fully operational by ticking the boxes below after installation is completed.	<b>Pass</b>	<b>Fail</b>	<b>N/A</b>
<b>Check</b>			
<b>Store introduction</b>			
Have you signed to the store?			
Have you informed the staff of the commissioning work you will be completing?			
<b>Gate arrangement</b>			
How many Gates sets are installed on this site? e.g. 1 Entry, 3 Exits	<b>Comment:</b>		
How many Sensors are installed on this site?	<b>Comment:</b>		
How many Scan master devices are installed on this site?	<b>Comment:</b>		
Is the correct SD card installed in each ScanMaster?			
Have all Scan masters been pinged and confirmed online by Radford?			
Do all ScanMaster initialize correctly (LED status)?			
Are ScanMaster DIP switch settings correct?			
Are all Sesame sensors installed as per floor plan and correct height?			
Are all sensors level, secure and lenses clean?			
Have all sensors been pinged and confirmed online by Radford?			
Is the network equipment installed and powered correctly? (Switch & internet modem)			



<b>ENTRY GATE CHECKIST</b>		<b>✓</b>	<b>✗</b>	
Installer to check that gates are fully operational by ticking the boxes below after installation is completed.		<b>Pass</b>	<b>Fail</b>	<b>N/A</b>
<b>Record Check</b>				
PHOTO	Are all dropper poles installed correctly and aligned with each gate?			
PHOTO	Are all cables routed correctly through dropper poles and protected?			
PHOTO	Are gate poles installed securely and aligned correctly?			
PHOTO	Are all fixings secure and suitable for the floor material with Chemset and tightened?			
PHOTO	Are rails and uprights aligned correctly?			
PHOTO	Are the gates connected to 220–240V power supply?			
PHOTO	Are the gates chassis correctly grounded?			
PHOTO	Is the isolation switch installed, labelled and accessible and controls all gates?			
VIDEO	Has the isolation switch been tested and confirmed operational?			
PHOTO	Are the gate arms installed correctly with all brackets and spacers?			
PHOTO	Are LED cables intact and not damaged during installation?			
PHOTO	Is the GateCOM synchronization cable installed and working on all gates?			
PHOTO	Are DIP switch settings correct?			
PHOTO	Are potentiometer settings correctly configured?			
VIDEO	Gates closing behind customer after 4 seconds.			
PHOTO	Are PEC sensors and reflectors installed correctly on the first pair if a second pair is present? Not needed if just 2 wide 1 deep kit			
PHOTO	Are approach radars installed on both sides of the first pair of gates?			
VIDEO	Gates Approach radar triggered at 2000mm. Min trigger distance 1500mm if necessary.			
VIDEO	Have radars been tested individually to confirm correct settings?			
VIDEO	Do gates open and close smoothly without obstruction?			
VIDEO	Do gate arms close at slow speed?			
VIDEO	Are gates working correctly as a pair (Master and Slave)?			
PHOTO	Is the remote receiver installed correctly in the gate body?			
PHOTO	Are DIP switches configured correctly for postcode and pairing?			
VIDEO	Are all remotes paired and functioning correctly with this gate?			
VIDEO	Remote button 2 latch gates to open (Should remain open until button 2 is pressed again)			
VIDEO	Remote button 4 latch gates to open together with all other gates (Should remain open until button 4 is pressed again).			
VIDEO	Has the key switch been tested?			



<b>Follow up work required:</b>				
N/A	Are you satisfied that the <b>finished</b> works are <b>compliant</b> , and the layout is suitable to perform its intended operations?			
N/A	Are there groundwork fixings <b>follow up</b> required?			
N/A	Are there any screws or rubber/plastic bungs needing <b>replacing</b> ?			
N/A	Are there any covers needing <b>replacement</b> ?			
N/A	Is there any equipment <b>left behind</b> for Bunnings perusal (if yes please was the store manager notified of location)?			

<b>EXPRESS EXIT GATE CHECKLIST</b>		<b>✓ Pass</b>	<b>✗ Fail</b>	<b>N/A</b>
Installer to check that gates are fully operational by ticking the boxes below after installation is completed.				
<b>Record</b>	<b>Check</b>			
PHOTO	Are all dropper poles installed correctly and aligned with each gate?			
PHOTO	Are all cables routed correctly through dropper poles and protected?			
PHOTO	Are gate poles installed securely and aligned correctly?			
PHOTO	Are all fixings secure and suitable for the floor material with Chemset and tightened?			
PHOTO	Are rails and uprights aligned correctly?			
PHOTO	Are the gates connected to 220–240V power supply?			
PHOTO	Are the gates chassis correctly grounded?			
PHOTO	Is the isolation switch installed, labelled and accessible and controls all gates?			
VIDEO	Has the isolation switch been tested and confirmed operational?			
PHOTO	Are the gate arms installed correctly with all brackets and spacers?			
PHOTO	Are LED cables intact and not damaged during installation?			
PHOTO	Is the GateCOM synchronization cable installed and working on all gates?			
PHOTO	Are DIP switch settings correct?			
PHOTO	Are potentiometer settings correctly configured?			
VIDEO	Gates closing behind customer after 4 seconds.			
PHOTO	Are PEC sensors and reflectors installed correctly on the first pair if a second pair is present? Not needed if just 2 wide 1 deep kit			
PHOTO	Are approach radars installed on both sides of the first pair of gates?			
VIDEO	Gates Approach radar triggered at 2000mm. Min trigger distance 1500mm if necessary.			
VIDEO	Have radars been tested individually to confirm correct settings?			
VIDEO	Do gates open and close smoothly without obstruction?			
VIDEO	Do gate arms close at slow speed?			
VIDEO	Are gates working correctly as a pair (Master and Slave)?			

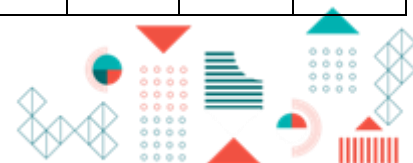

PHOTO	Is the remote receiver installed correctly in the gate body?			
PHOTO	Are DIP switches configured correctly for postcode and pairing?			
VIDEO	Are all remotes paired and functioning correctly with this gate?			
VIDEO	Remote button 4 latch gates to open together with all other gates (Should remain open until button 4 is pressed again).			
VIDEO	Has the key switch been tested?			
<b>Follow up work required:</b>				
N/A	Are you satisfied that the <b>finished</b> works are <b>compliant</b> , and the layout is suitable to perform its intended operations?			
N/A	Are there groundwork fixings <b>follow up</b> required?			
N/A	Are there any screws or rubber/plastic bungs needing <b>replacing</b> ?			
N/A	Are there any covers needing <b>replacement</b> ?			
N/A	Is there any equipment <b>left behind</b> for Bunnings perusal (if yes please was the store manager notified of location)?			

<b>MAIN REGISTER EXIT GATE (with Sesame) CHECKLIST</b>		<b>✓</b>	<b>✗</b>	
Installer to check that gates are fully operational by ticking the boxes below after installation is completed.		<b>Pass</b>	<b>Fail</b>	<b>N/A</b>
<b>Record</b>	<b>Check</b>			
PHOTO	Are all dropper poles installed correctly and aligned with each gate?			
PHOTO	Are all cables routed correctly through dropper poles and protected?			
PHOTO	Are gate poles installed securely and aligned correctly?			
PHOTO	Are all fixings secure and suitable for the floor material with Chemset and tightened?			
PHOTO	Are rails and uprights aligned correctly?			
PHOTO	Are the gates connected to 220–240V power supply?			
PHOTO	Are the gates chassis correctly grounded?			
PHOTO	Is the isolation switch installed, labelled and accessible and controls all gates?			
VIDEO	Has the isolation switch been tested and confirmed operational?			
PHOTO	Are the gate arms installed correctly with all brackets and spacers?			
PHOTO	Are LED cables intact and not damaged during installation?			
PHOTO	Is the GateCOM synchronization cable installed and working on all gates?			
PHOTO	Are DIP switch settings correct?			
PHOTO	Are potentiometer settings correctly configured?			
VIDEO	Gates closing behind customer after 4 seconds.			
VIDEO	Gates closing after 6 seconds if triggered to open, when no customer passed through the gate.			
PHOTO	Are PEC sensor and reflector installed correctly on the gate?			



VIDEO	Do gates open and close smoothly without obstruction?			
VIDEO	Do gate arms close at slow speed?			
VIDEO	Are gates working correctly as a pair (Master and Slave)?			
PHOTO	Is the remote receiver installed correctly in the gate body?			
PHOTO	Are DIP switches configured correctly for postcode and pairing?			
VIDEO	Are all remotes paired and functioning correctly with this gate?			
VIDEO	Remote button 1 triggering gates to open (then auto close after 4 seconds once someone walks through).			
VIDEO	Remote button 4 latch gates to open together with all other gates (Should remain open until button 4 is pressed again).			
VIDEO	Has the key switch been tested?			
<b>Follow up work required:</b>				
N/A	Are you satisfied that the <b>finished</b> works are <b>compliant</b> , and the layout is suitable to perform its intended operations?			
N/A	Are there groundwork fixings <b>follow up</b> required?			
N/A	Are there any screws or rubber/plastic bungs needing <b>replacing</b> ?			
N/A	Are there any covers needing <b>replacement</b> ?			
N/A	Is there any equipment <b>left behind</b> for Bunnings perusal (if yes please was the store manager notified of location)?			

<b>SERVICE DESK EXIT GATE (with Sesame) CHECKLIST</b>		<b>✓</b>	<b>X</b>	
Installer to check that gates are fully operational by ticking the boxes below after installation is completed.		<b>Pass</b>	<b>Fail</b>	<b>N/A</b>
<b>Record</b>	<b>Check</b>			
PHOTO	Are all dropper poles installed correctly and aligned with each gate?			
PHOTO	Are all cables routed correctly through dropper poles and protected?			
PHOTO	Are gate poles installed securely and aligned correctly?			
PHOTO	Are all fixings secure and suitable for the floor material with Chemset and tightened?			
PHOTO	Are rails and uprights aligned correctly?			
PHOTO	Are the gates connected to 220–240V power supply?			
PHOTO	Are the gates chassis correctly grounded?			
PHOTO	Is the isolation switch installed, labelled and accessible and controls all gates?			
VIDEO	Has the isolation switch been tested and confirmed operational?			
PHOTO	Are the gate arms installed correctly with all brackets and spacers?			
PHOTO	Are LED cables intact and not damaged during installation?			
PHOTO	Is the GateCOM synchronization cable installed and working on all gates?			
PHOTO	Are DIP switch settings correct?			
PHOTO	Are potentiometer settings correctly configured?			



VIDEO	Gates closing behind customer after 4 seconds.			
VIDEO	Gates closing after 6 seconds if triggered to open, when no customer passed through the gate.			
PHOTO	Are PEC sensor and reflector installed correctly on the gate?			
VIDEO	Do gates open and close smoothly without obstruction?			
VIDEO	Do gate arms close at slow speed?			
VIDEO	Are gates working correctly as a pair (Master and Slave)?			
PHOTO	Is the remote receiver installed correctly in the gate body?			
PHOTO	Are DIP switches configured correctly for postcode and pairing?			
VIDEO	Are all remotes paired and functioning correctly with this gate?			
VIDEO	Remote button 4 latch gates to open together with all other gates (Should remain open until button 4 is pressed again).			
VIDEO	Has the key switch been tested?			
<b>Follow up work required:</b>				
N/A	Are you satisfied that the <b>finished</b> works are <b>compliant</b> , and the layout is suitable to perform its intended operations?			
N/A	Are there groundwork fixings <b>follow up</b> required?			
N/A	Are there any screws or rubber/plastic bungs needing <b>replacing</b> ?			
N/A	Are there any covers needing <b>replacement</b> ?			
N/A	Is there any equipment <b>left behind</b> for Bunnings perusal (if yes please was the store manager notified of location)?			



## 14. Store sign off

The installation team is responsible for completing the below store sign off with a store manager.

The records should be consolidated and sent to [support@radfordretail.com](mailto:support@radfordretail.com) as records of a successfully completed installation together with the installation & commissioning sign off checklist.

Store Sign Off	✓ Pass	✗ Fail	N/A
Installer to check that gates are fully operational by ticking the boxes below after installation is completed.			
<b>Check</b> <i>Store introduction</i>			
Have you completed hand over training with an available manager?			
Provide image of hand over remotes and keys.			
<b>Store representative Name &amp; Signature</b>			
<b>Technician that completed commissioning Name &amp; Signature</b>			

