

SigmaGate & Sesame 2

EXIT SOLUTION

Coles SigmaGate & Sesame 2 - Installation Manual
MPB 2.0 bracket

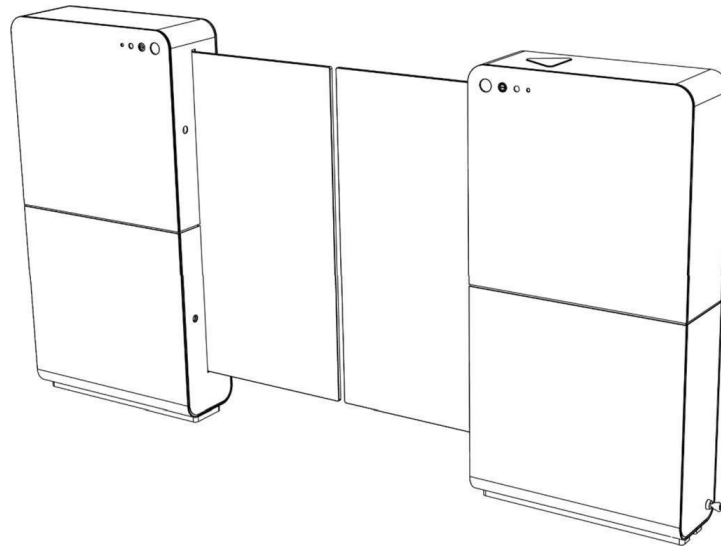

Version control

Version	Date	Comments	Issued by
1.0	13/04/2026	<ul style="list-style-type: none">Chapter 8, page 10: Updated all dimensions to accommodate the MPB 2.0 bracket.Chapter 9, pages 11 – 21: Updated gate mounting and wiring instructions to MPB 2.0 bracket version.Chapter 10, page 22: Updated ethernet connection instructions with MPB 2.0 bracket.	Jonathan Gunnarsson

Table of Contents

1.	Sesame 2/SigmaGate system introduction	4
2.	Contact Information	5
3.	Shipment Content with MPB	5
4.	Install drop down poles	6
5.	Install data cables to sensors	7
6.	Install the Store tacker (and Spider device if needed)	8
7.	Unpack SigmaGate with MPB	9
8.	SigmaGate Dimensions with MPB 2.0 function (EXIT)	10
9.	Mounting of a SigmaGate with MPB 2.0.....	11
9.1.	Prepare the site	11
9.2.	Mark where to drill	11
9.3.	Drill the holes	11
9.4.	Ensure the floor is level	11
9.5.	Fasten the bracket to the floor	12
9.6.	Sideways levelling.....	12
9.7.	Adjust the front wheel.....	13
9.8.	Set the Mechanical Panic Breakout (MPB) holder	14
9.9.	Set MPB force	14
9.10.	Set the Mechanical Panic Breakout Trigger	15
9.11.	Align two SigmaGate MPB 2.0	16
9.12.	MPB cover	17
9.13.	Connectors cover.....	17
9.14.	Cable routing	18
9.15.	Connect GateCOM cabling.....	19
9.16.	SigmaGate isolation switch installation	20
9.17.	Connect incoming power 220 – 240V	21
9.18.	Mount bracket cover	21
10.	Connection of Ethernet	22
11.	Adjustment of Gate PEC	23
12.	Customer Facing Safety Radar installation	24
13.	Adjustment of Glass Door.....	31
14.	Configuration of ScanMaster 2.0.....	32
15.	DIP-switch settings ScanMaster.....	33
16.	Master & Slave Dip Switch Settings	34
17.	Master & Slave Potentiometer settings.....	35
18.	Check the gate timing using the ScanMaster board	36
19.	Remote Installation (Gen 3 Remotes).....	37
19.1.	Wire the Receiver to SigmaGate Control Board.....	38
19.2.	Mount the receiver.....	39
19.3.	Set the DIP Switches & Pair Remotes	42
20.	Remote monitoring cable	44
21.	Commissioning sign-off checklist.....	45
22.	Store manager declaration	46
23.	Troubleshooting Schedule	47

1. Sesame 2/SigmaGate system introduction

The ITAB Sesame 2/Sigma system is a unique system fully developed by Itab AB Sweden that incorporates patented software.

Sesame 2 is designed to identify the customer who has fully completed payment for the purchase of goods at the checkout POS terminal.

This payment confirmation was achieved via a series of overhead camera sensors (loaded with Itab IP software) profiling the people standing next to the payment terminal at the same moment their payment has been validated through the same checkout payment terminal.

Upon validation by the store POS payment terminal a signal is instantaneously sent to a device (usually installed at the back end of the store) known as a storetracker (also loaded with Itab IP software) and validates a customer using the overhead mounted camera sensors.

At the physically controlled exit point, a set of SigmaGates are installed to create a physical barrier to non-paid customers and only opening for the paid and validated customer as they approach a pre-set distance to the SigmaGate.

After the paid customer passes through the gates, they return to their normally closed position thereafter awaiting the next paid customer to approach.

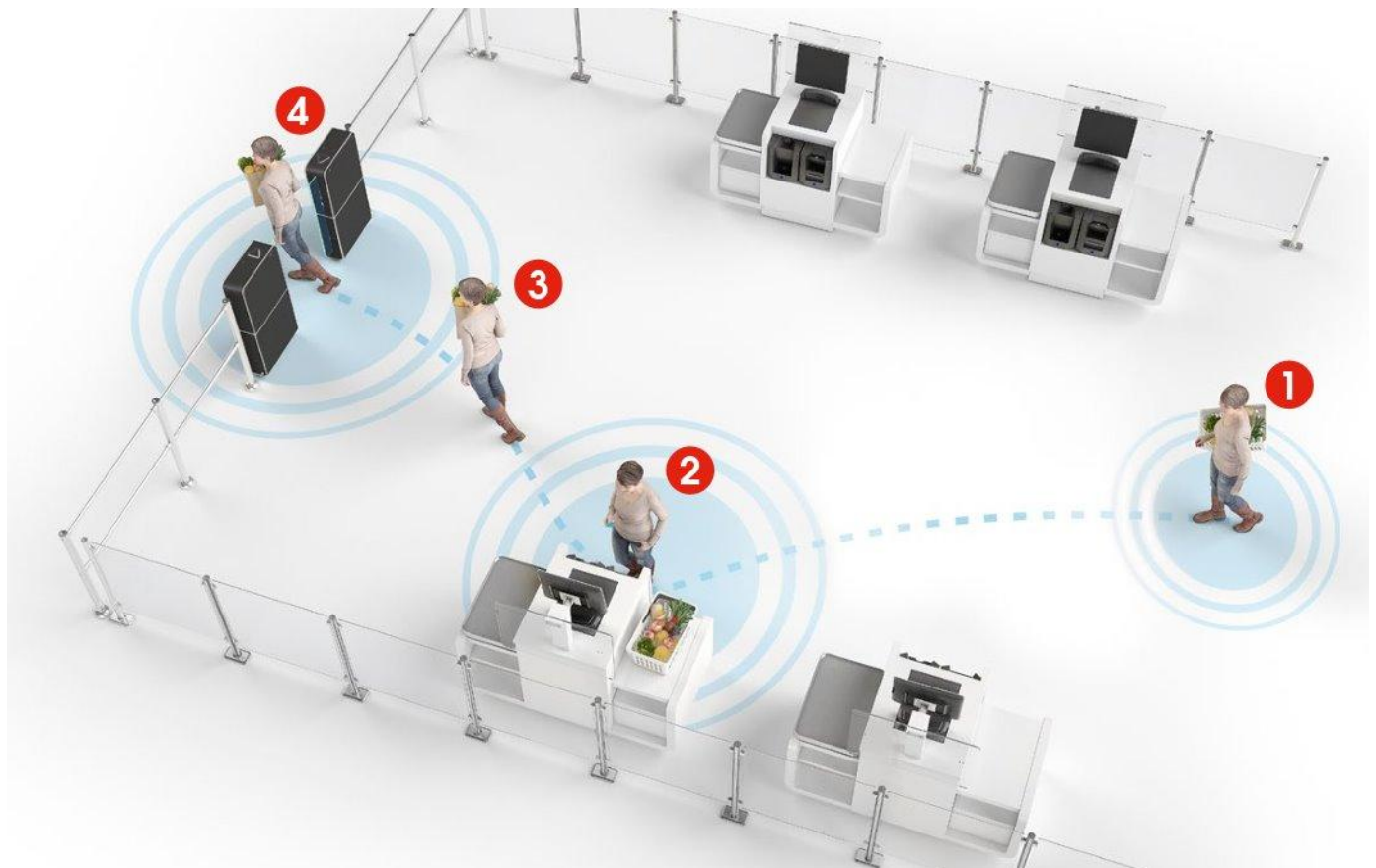

2. Contact Information

Shipping address: Unit 6/ 5-7 Malta St Fairfield East

Software support – support@radfordretail.com

Service – service@radfordretail.com

Knowledge base - <https://radfordretail.zendesk.com/hc/en-au>

3. Shipment Content with MPB

Note

Make sure that the following content is delivered before starting installation. Below content is based on a saloon installation of SigmaGates. Keys are attached with cable ties behind the service hatch.

- SigmaGate MPB
- Base plate lifter kit
- Forth fixing
- Split junction box
- Drilling template

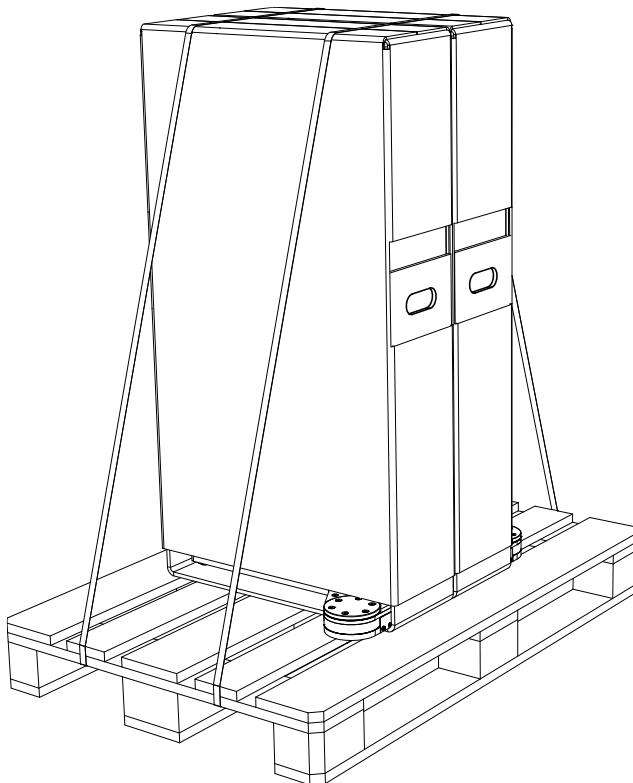

4. Install drop down poles

To install the SigmaGate/Sesame 2 system into the front-end self-scan area (or conventional checkout area) please follow the below steps:

Install drop down poles and mount camera sensors, precisely as located from store drawing – store drawing to be provided by the builder.

Important notes on installing Xovis sensors onto the drop-down poles:

- a) Must be installed as per matching ID as each sensor will have its own IP address and location above the floor – check with to ensure the correct Xovis sensor match the overhead floor location.
- b) Must be installed at a specific height.
- c) Must be Installed Level.
- d) Must be installed rigidly to prevent movement.
- e) Must be installed as per individual store drawing – check with builder as dimensions (floor location & height from floor) are critical and will vary from site to site.
- f) Must be kept free from dust and grease.



5. Install data cables to sensors

Install data cables (cat7 or higher are recommended) as plug & play cables to each Xovis sensor and spider (if required) to Coles network (Xovis sensors front-end coms cabinet and spider (if included) the Coles network via the backend coms cabinet.

Note: If more than nine Xovis sensors are used, an additional device (spider) will also have to be connected to the network. See drawing below showing a typical schematic of the sesame 2 hardware.

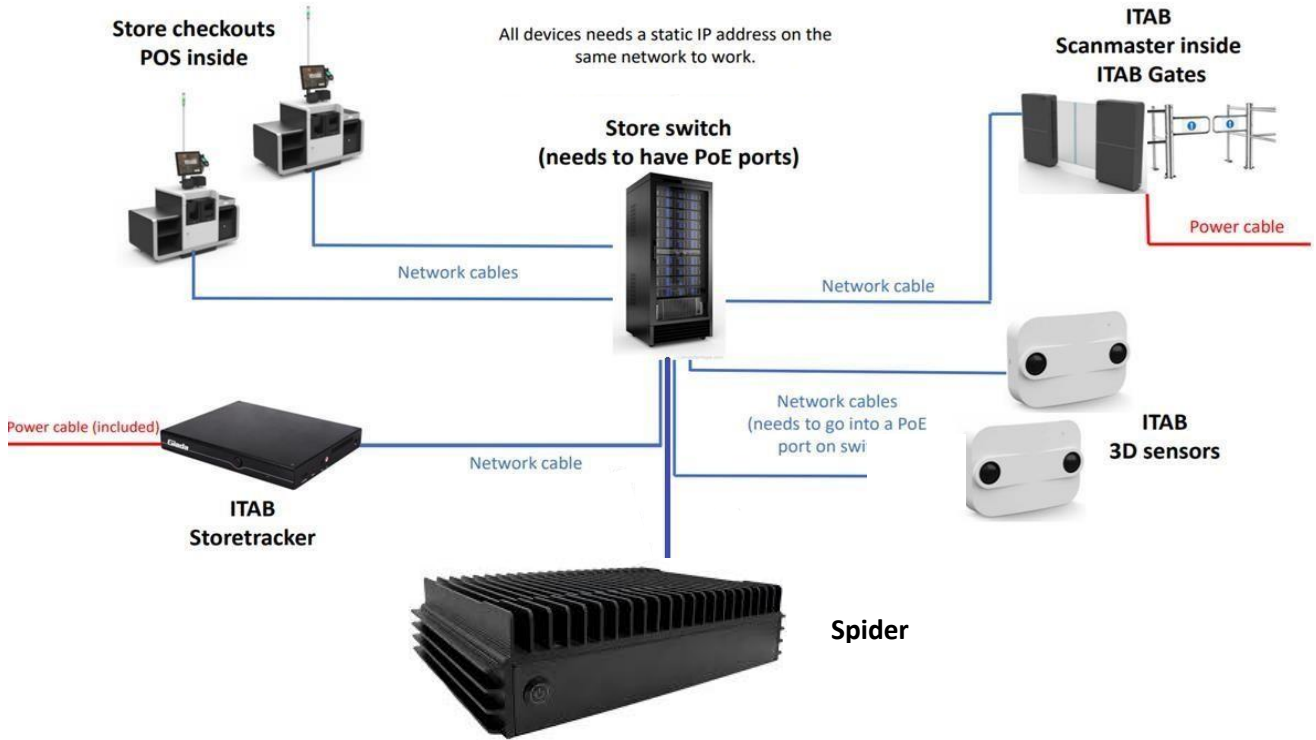

Note: Store checkouts and POS systems are already connected to the store switch, and it is not necessary/required to run additional patch leads to the checkouts.

6. Install the Store tacker (and Spider device if needed)

Store trackers and Spider devices are to be placed in the comms cabinet (see site manager for cabinet number) and be plugged into a 240v-power outlet using the power cables provided.

Connect store tracker and Spider to the switch using a cat7 or higher network cable. Plug one end of network cable into the programmed port (the one with the IP address next to it) and the other end of the network cable into the designated port in the comms cabinet. See IP tracker for port number.



Please note that a spider is only needed if more than nine sensors are being used in the same zone.

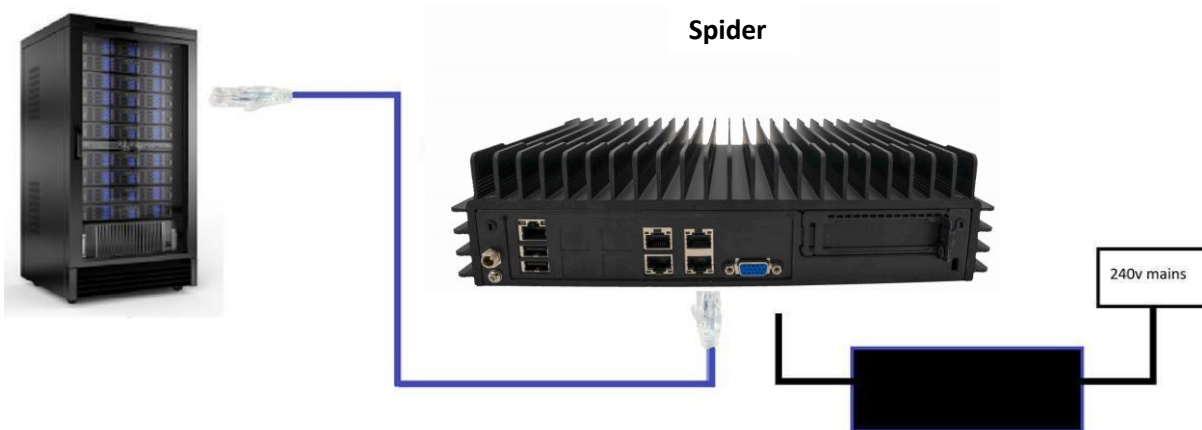

7. Unpack SigmaGate with MPB

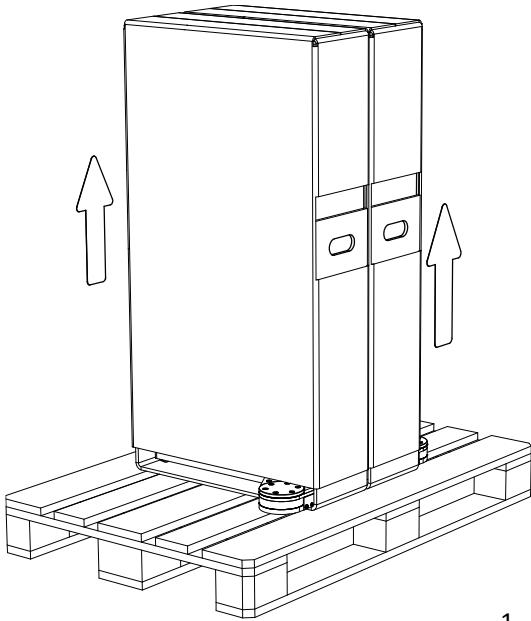

⚠ WARNING

The SigmaGate are heavy. Be careful and don't lift it higher than necessary for removing it from the pallet.

1. Use the handles to remove the SigmaGates from the pallet.

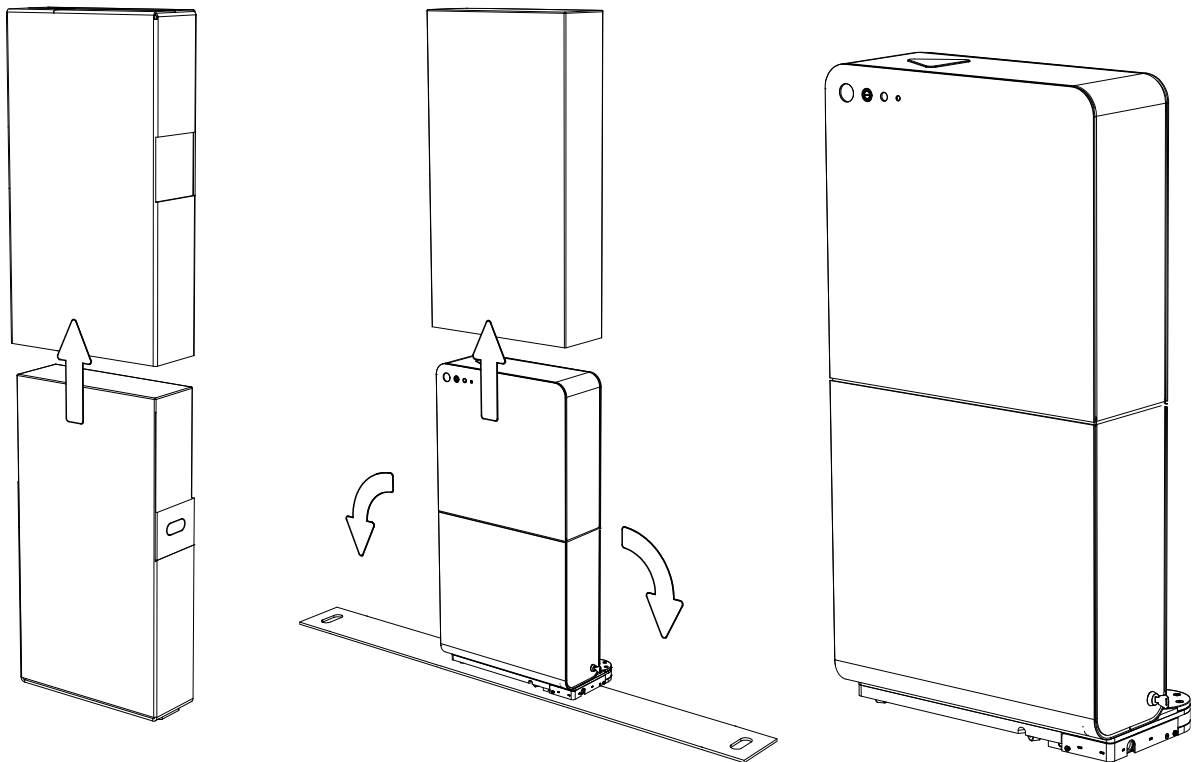

2. Lift the packaging and remove the SigmaGate.

8. SigmaGate Dimensions with MPB 2.0 function (EXIT)

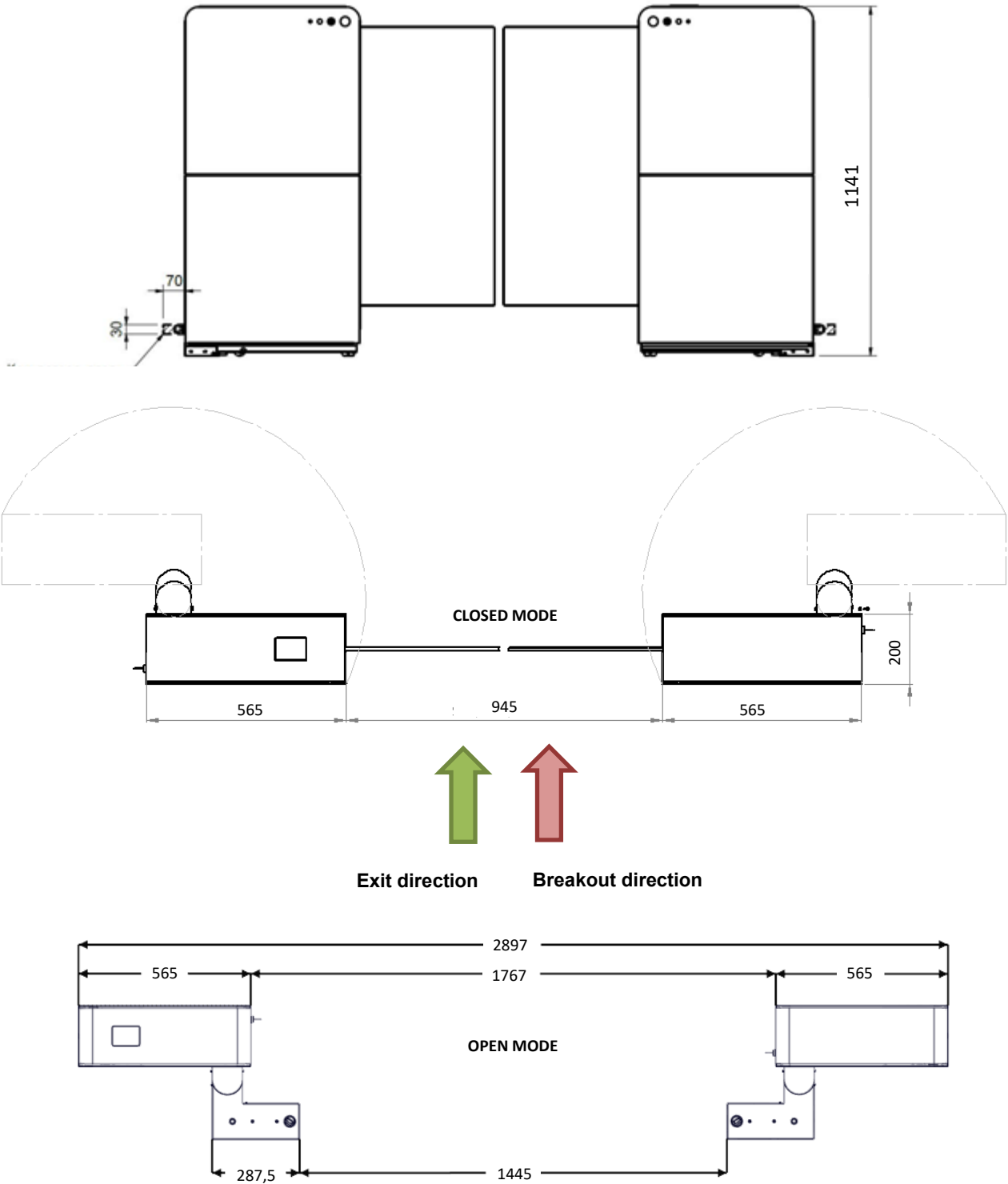

Do not place the gates closer than 70 mm to nearest object.
 (Standard ITAB uprights can be placed as close as the foot cover allows as long as the key switch is not blocked)

9. Mounting of a SigmaGate with MPB 2.0

9.1. Prepare the site

Make sure the floor where SigmaGate MPB 2.0 will be placed is flat and clean.

9.2. Mark where to drill

If available, use a drilling template and place it on the floor where SigmaGate MPB 2.0 is to be located. Then, mark where to drill.

If no template is available, use the gate bracket as a guide to mark the drilling points.

Note: Increase the template dimensions by 45 mm to achieve a 75 mm gap between the glass doors (up from the standard 30 mm).

Make sure the distance **from inner bracket edges is measured to 1445 mm**. See all dimensions on pages 7 to 9.

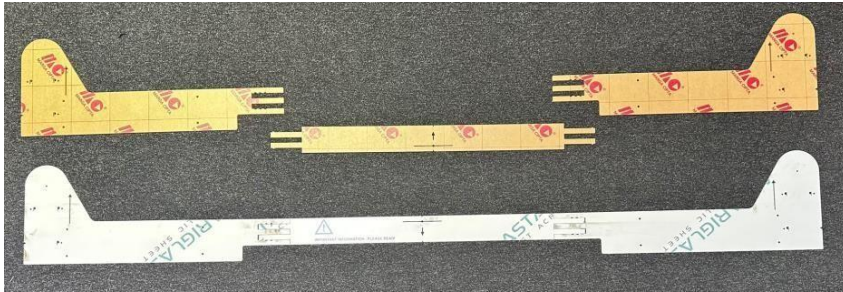

9.3. Drill the holes

Drill hole positions should be marked in advance for the fasteners for each SigmaGate MPB 2.0.

Drill holes up to a maximum diameter of **Ø10 mm to suit M8 fixings**.

This provides appropriate clearance for installation.

It is recommended to use **5 × M8 × 75 mm bolts per gate bracket**.

Ensure the hole depth is suitable for the selected fasteners and the floor construction.

When installing a pair of SigmaGate MPB 2.0 in parallel, ensure both drill templates are accurately aligned. Proper alignment is critical to keep the gates parallel and to ensure smooth operation without misalignment.

Chemical anchoring must be used for all installations.

The installer must select a suitable chemical anchoring product based on the floor material and condition.

Fixing type and embedment depth must be determined on site to ensure adequate strength and long-term stability of the installation.

9.4. Ensure the floor is level

When installing a pair of SigmaGate MPB 2.0, it's especially crucial to ensure that the floor is level.

Proper levelling is important both for the functionality of the gates and for their aesthetic appearance.

An uneven floor can lead to operational issues and detract from the visual symmetry between the paired gates.

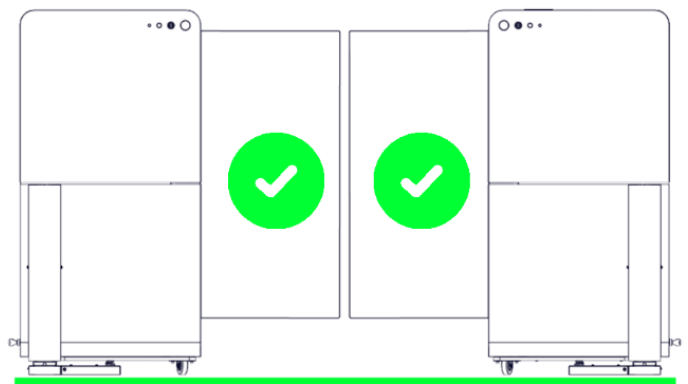
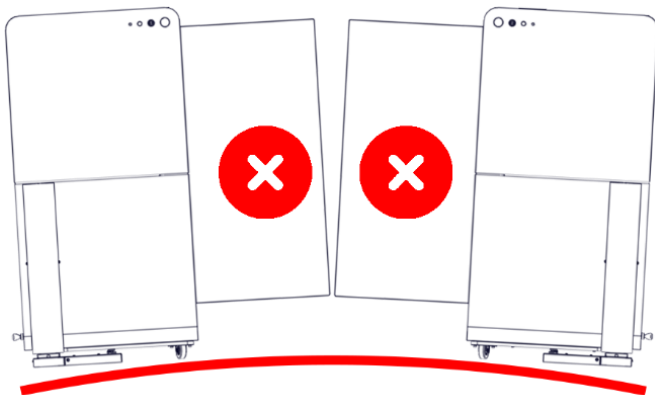

9.5. Fasten the bracket to the floor

Place SigmaGate MPB 2.0 over the predrilled holes and align the bracket with the hole pattern (5). Secure the bracket using **5 × M8 × 75 mm bolts per bracket** as recommended.

Install the anchors according to the manufacturer's instructions, ensuring correct embedment depth and curing time before applying load.

Chemical anchoring must be used for all installations

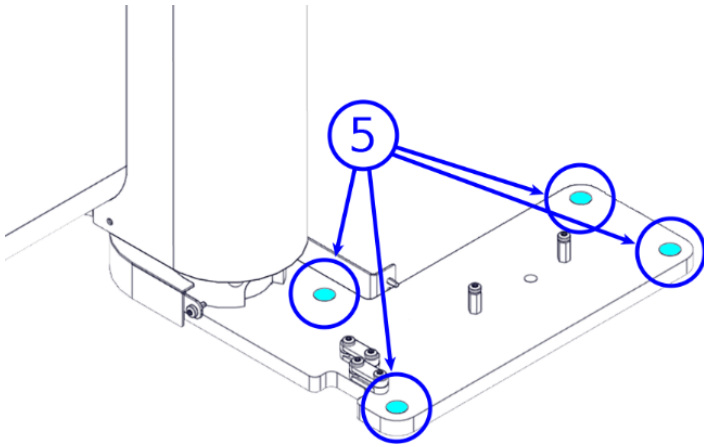

NOTE
 Always ensure that no fixing materials or chemical cement are present between the floor and the gate's bracket when securing the gate bracket to the floor.



Note: It is very important to ensure base plates sits above floor tile level.
 If the fasteners are not holding the MPB block strong enough to the floor, the gate position can be incorrect leading to interrupted photocell signals and faulty behavior of the gates. To prevent this, the five holes must be filled with chemical anchoring to lock the position after making sure the gates are in line with each other. Ensure all fasteners are tightened securely and the bracket is firmly fixed to the floor.

9.6. Sideways levelling

To level SigmaGate MPB 2.0 sideways, it is possible to use shims under the bracket. To place shims under the bracket, first, loosen the fastening bolts. Then, put the shims between the floor and the bracket where needed. After using a spirit level to ensure the gate is level retighten the bolts properly.

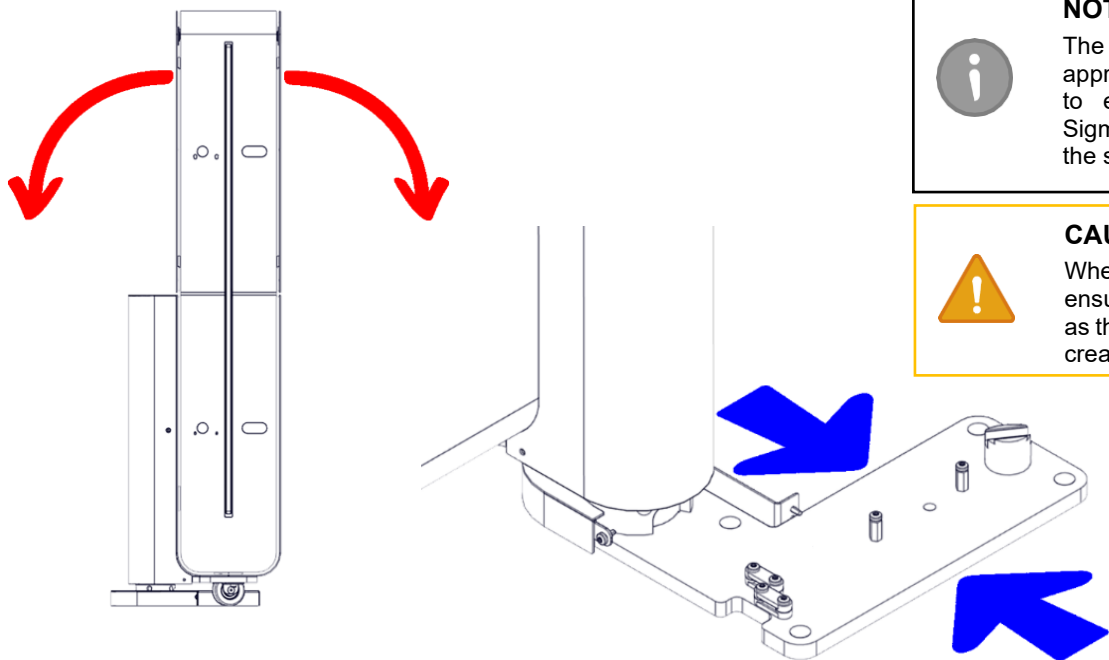

NOTE
 The shims used should be of an appropriate material and large enough to ensure they do not destabilize SigmaGate MPB 2.0. Use only shims at the sides indicated in the image.

CAUTION
 When installing SigmaGate MPB 2.0, ensure that the cables are not pinched, as this can lead to product damage and create a safety hazard.

9.7. Adjust the front wheel

It is possible to further level SigmaGate MPB 2.0 by adjusting the height of the front wheel.

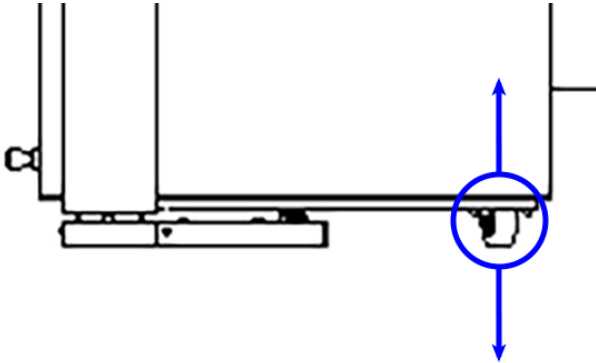

Start by loosening the locking nut (2)

Use the wheel adjustment screw (1), which is located inside at the front end of SigmaGate MPB 2.0.

By tightening the screw, you will lower the wheel and loosening it will raise the wheel.

After adjusting the wheel to the desired height, retighten the locking nut (2) to secure the wheel in its new position.

These steps allow you to effectively control the positioning of the front wheel, enhancing the functionality and stability of SigmaGate MPB 2.0.

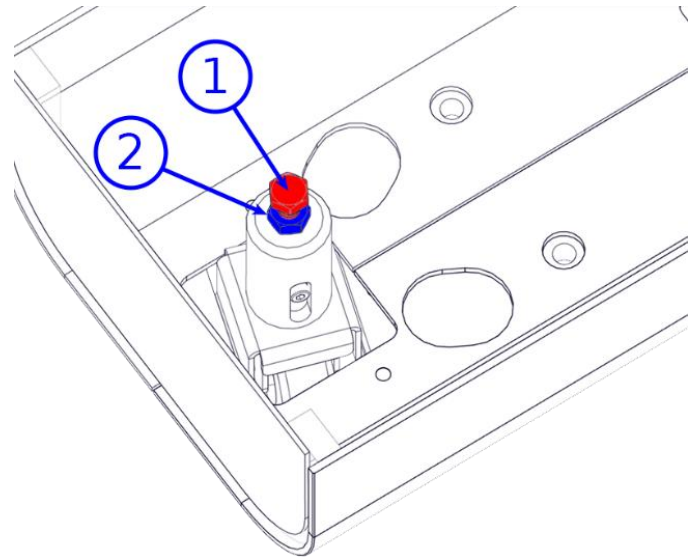

NOTE

The front wheel should always be in contact with the floor.

9.8. Set the Mechanical Panic Breakout (MPB) holder

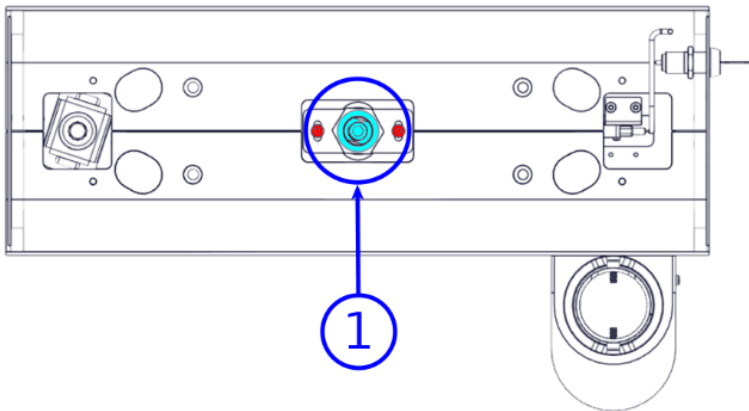

Follow the steps below to adjust the MPB holder to the correct height:

1. Untighten the locking nut (1) with a wrench (36 mm).
2. Turn the MPB holder (1) clockwise until the bottom of the holder just touches the bracket. You may need an 18 mm wrench to do this.
3. Turn the MPB holder (1) half turn anticlockwise to create a small distance between the MPB holder and the bracket.
4. Retighten the locking nut (1).

Always test the function after adjusting.

9.9. Set MPB force

The default MPB force for **SigmaGate MPB 2.0** is factory set to a maximum of **110N**, measured 1000 mm from the floor level and at the outer edge of the gate door.

Should it be necessary to change the MPB force it can be adjusted with the 8 mm Allen bolt.

Turn the Allen bolt anticlockwise to decrease the MPB force.

If the MPB force has been decreased earlier, it can be increased by turning the Allen bolt clockwise.

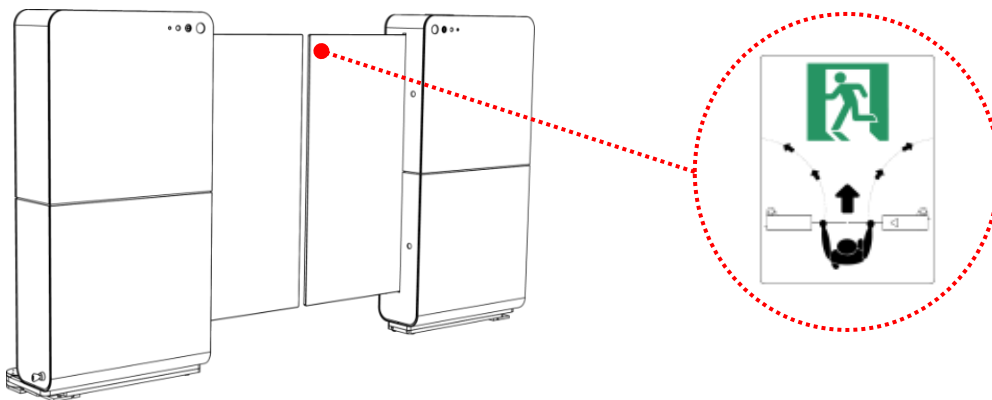

9.10. Set the Mechanical Panic Breakout Trigger

The Mechanical Panic Breakout (MPB) trigger (1) is set using the MPB trigger adjustment screw, which is located on the side of the upper part of the MPB column.

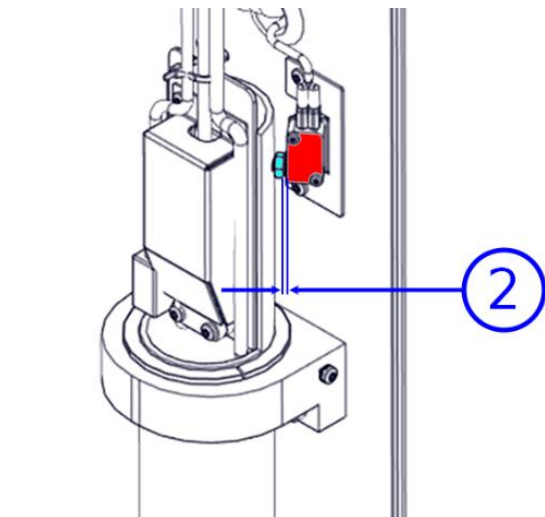
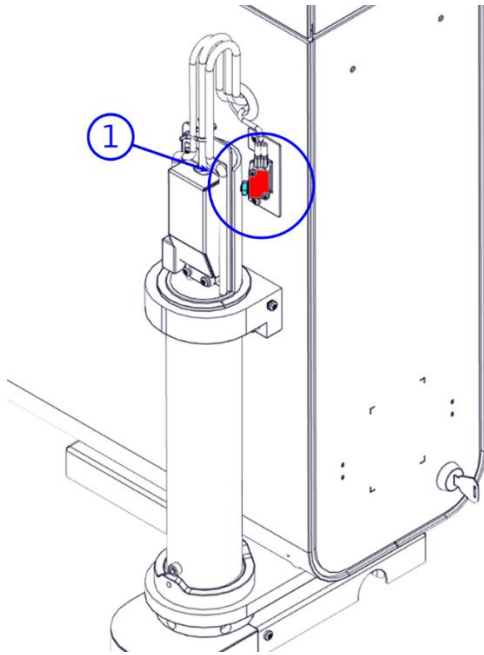

MPB trigger gap (2)

To adjust the MPB trigger correctly, follow these steps:

1. Remove the MPB cover to expose the MPB trigger adjustment.
2. Adjust the MPB trigger adjustment screw clockwise until the LED indicator on the bottom of the MPB sensor emits a steady yellow light, indicating that the MPB trigger adjustment screw is correctly adjusted. The gap is normally around 1 mm.
3. Test the function by pushing the gate open. The gate should trigger the alarm.

Note: The alarm should not activate in response to a light or minor push.

9.11. Align two SigmaGate MPB 2.0



If two parallel mounted SigmaGate MPB 2.0 need fine alignment after they have been secured to the floor the alignment can be fine adjusted. To align two gates, follow these steps:

Start by loosening the two Allen bolts **(1)** located at the bottom part of each gate. These bolts allow for adjustments to be made to the gate's position.

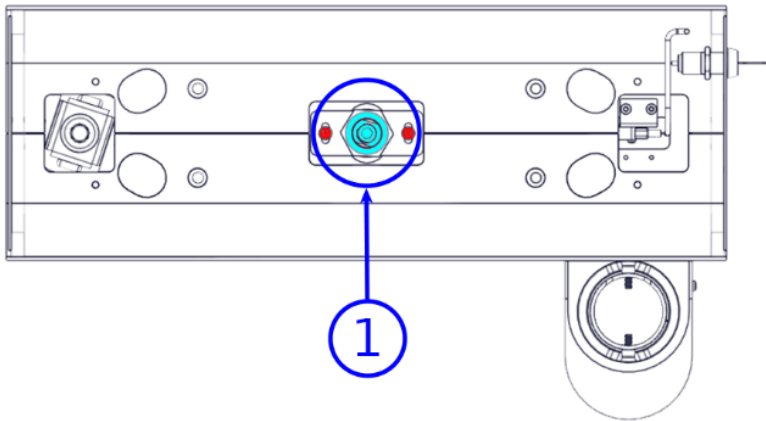

Use a straightedge or a similar tool to check the alignment of the two gates. Adjust the position of each gate until they are perfectly aligned with each other.

Once the gates are aligned correctly, retighten the Allen bolts **(1)** to secure the gates in their new positions. Make sure the bolts are tight enough to hold the gates firmly, but avoid overtightening, which could damage the bolts.

The above steps ensure that the gates are aligned not just for functional performance but also for aesthetic consistency.

9.12. MPB cover

To remove the MPB cover (1), unscrew the screws (2) shown in the picture.

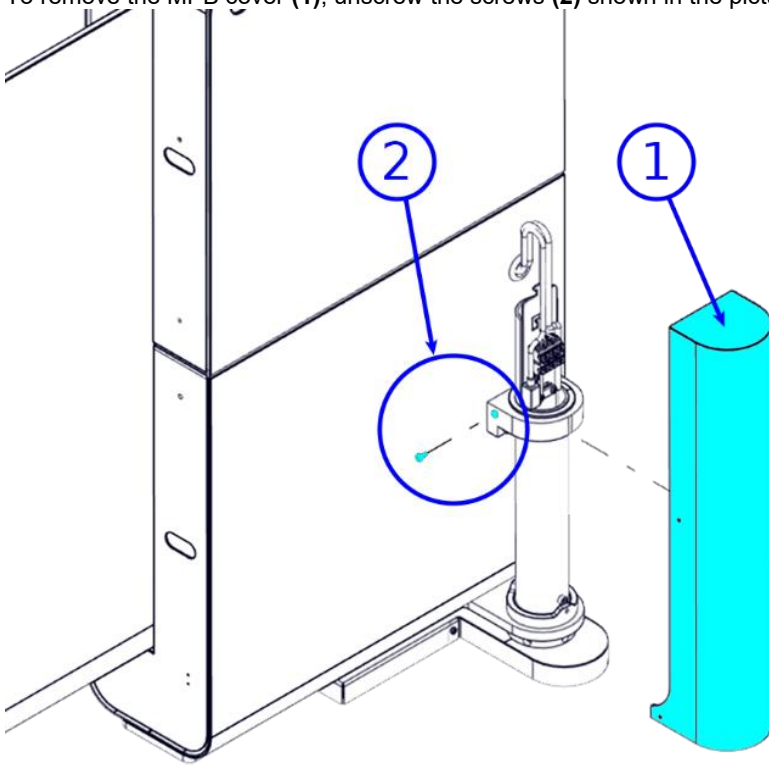

9.13. Connectors cover

Remove the connectors cover with the four screws (1).

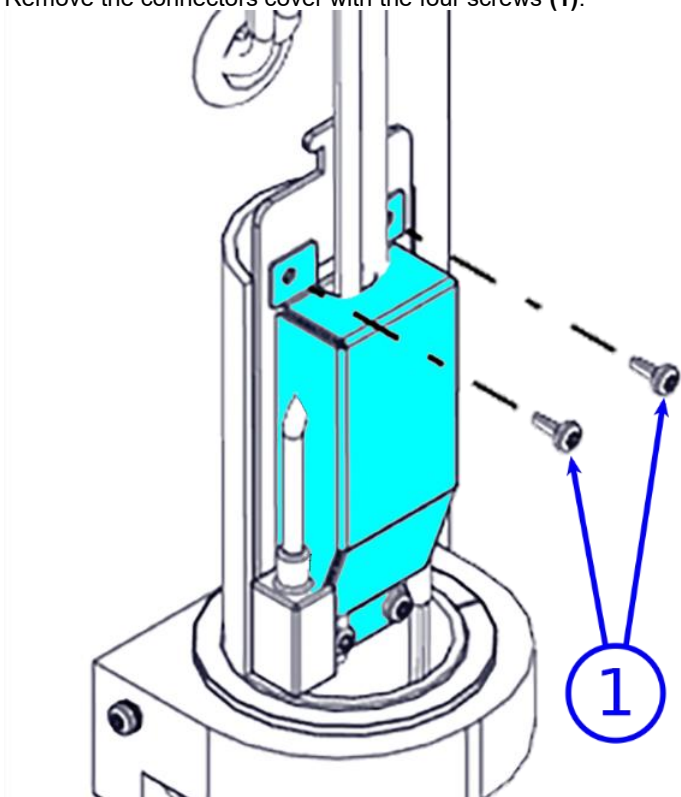

9.14. Cable routing

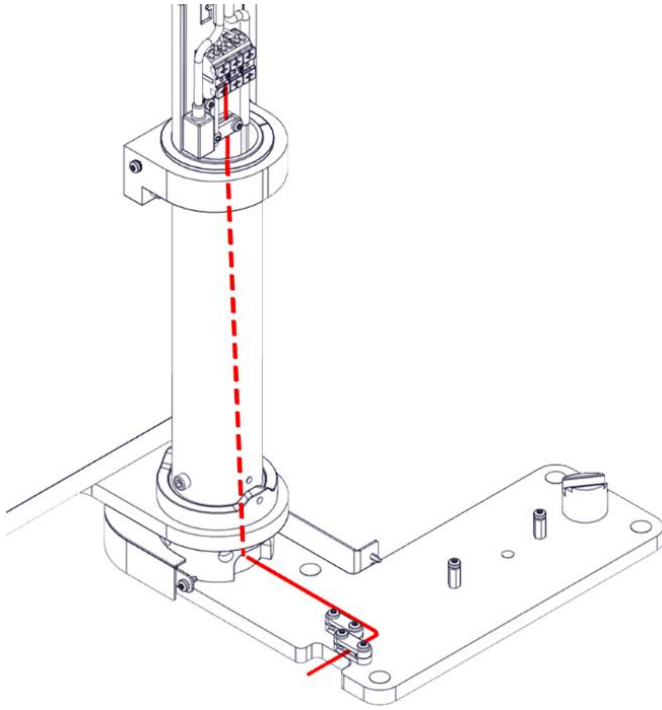

Route the power, and GateCOM signal cables as shown in the picture, and secure them using the two cable strain reliefs. Ensure that some slack is left in the cables to allow the gate to move without causing damage. The hole at the bottom of the pillar measures approximately 20×10 mm.

When routing cables, ensure that there are no sharp grades, bends or tight angles that could damage the cables. Confirm that all cables are properly routed, correctly positioned, and free from being pinched or strained.

Note: Do not store any excess cable inside SigmaGate MPB 2.0.

9.15. Connect GateCOM cabling

The electrical connections are located behind the connectors cover. Connect the incoming GateCOM/sync cable and any other signal cable going into the gate as per the instructions below. The GateCOM cable needs to be connected between the gates.

Incoming cabling

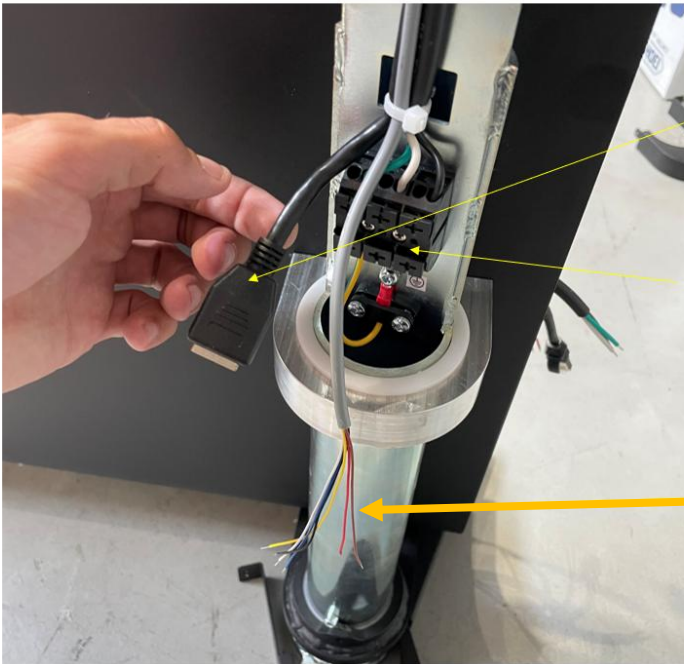

Connect gatecom cable between the gates (this 6-core cable can also be used for the fire alarm or other functions).

Note: Use recommended cables with nominal cross section area 1.5 – 2.5 mm².

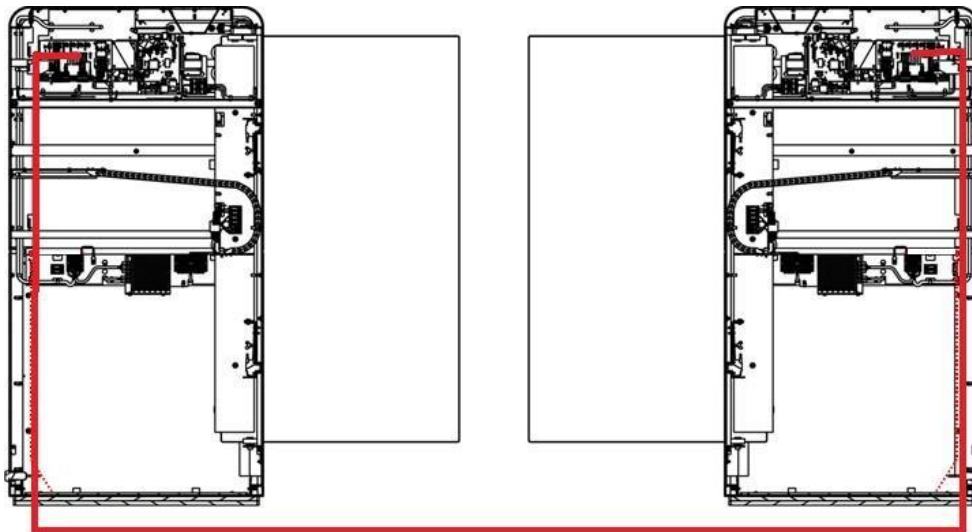

9.16. SigmaGate isolation switch installation

The isolation switch provides a dedicated means to disconnect power to the exit gate for servicing, maintenance, or emergency shutdown.

Requirements:**Switch type:**

- 10A minimum grey isolator, *Clipsal IP56 Series 56SW110-GY* (or equivalent).

Labelling:

- Must be clearly labelled "EXIT GATE POWER."

Ingress protection:

- Minimum IP56 rating for moisture and dust protection.

Circuit connection:

- Install a dedicated UPS circuit if necessary.
- Ensure total gate load (120 W max per gate) does not overload the circuit.

Installation notes

- All wiring must comply with AS/NZS 3000 electrical standards.
- Coordinate location and connection with the electrical contractor responsible for gate power routing.
- Verify isolator function as part of commissioning and handover testing.



9.17. Connect incoming power 220 – 240V

The power connection terminal block is located behind the same connectors cover as where the GateCOM cables were connected.

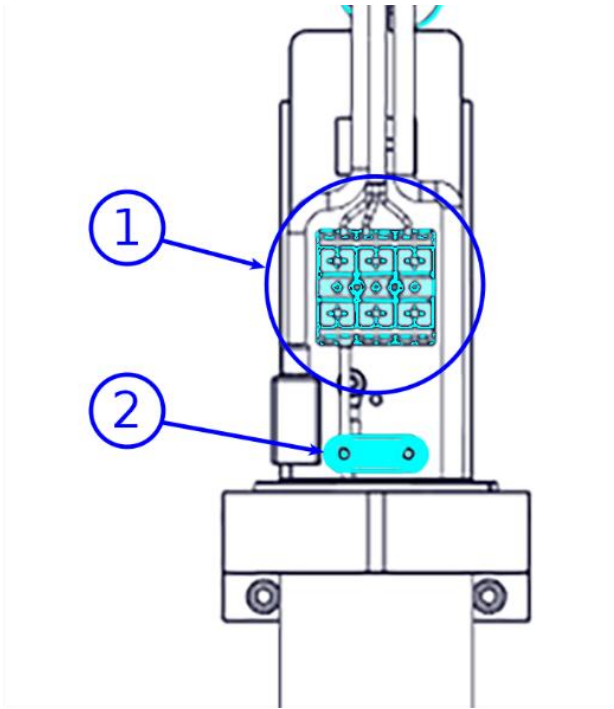

Connect SigmaGate MPB 2.0 to Mains 220 - 240V by following these steps:

1. Adjust the cable length.
2. Connect the cable to the terminal block **(1)** according to the markings on the terminal.
3. Fasten the cable to the strain relief **(2)**.

9.18. Mount bracket cover

Place the bracket cover **(6)** and fasten them with the provided screws.

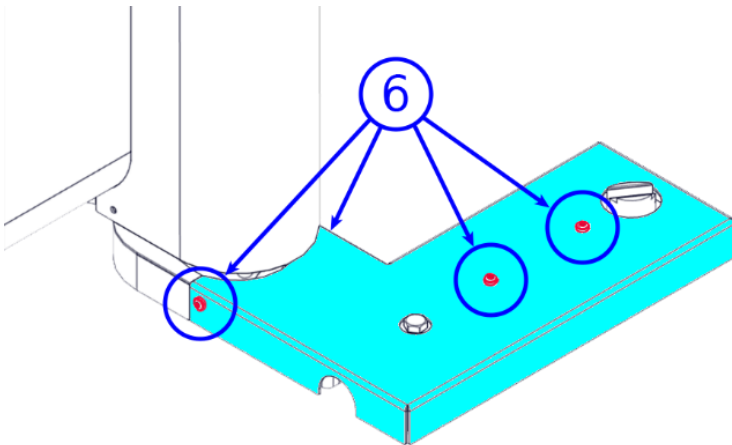

10. Connection of Ethernet

The SigmaGate is equipped with a ScanMaster on the right-hand side gate (right from when exiting through the gate) and is intended to be connected to the store POS system an Ethernet cable (cat7 or higher are recommended) needs to be connected to the ScanMaster 2.0.

Cable terminations

Radford recommends either of the two following options:

Option 1

Data cable is to be run from comms cabinet directly to the ScanMaster board with no breaks in the cable. Tech must bypass the data cable in the MPB bracket at the base of the gate. (see green dotted line below of how to rout the cable inside the gate)

Or

Option 2

The data cable is connected to the RJ45 connector in the base plate (data cable with suitable protective sleeve or shroud). An additional cable must go from the other RJ45 connector in the base plate up to the ScanMaster. (See the green dotted line below which is the data cable routing path)

Disclaimer: The ultimate responsibility of the cable terminations of this equipment lies with the licensed installers.

Option 1 ethernet connection

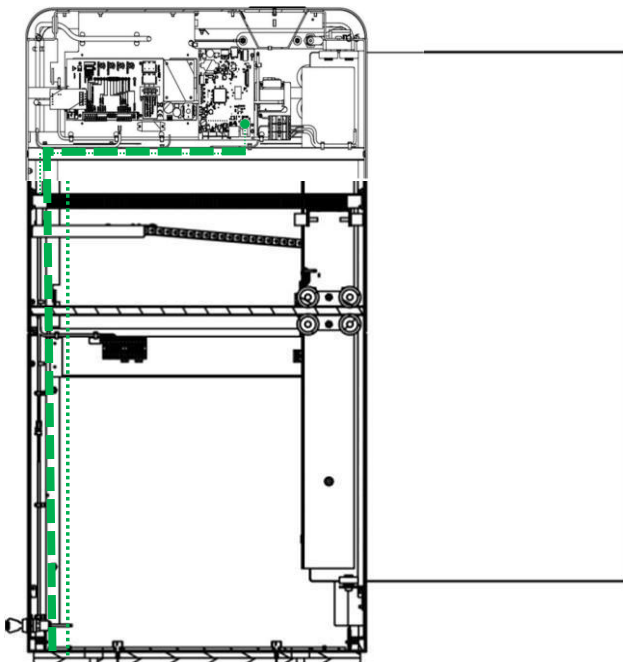

Option 2 ethernet con

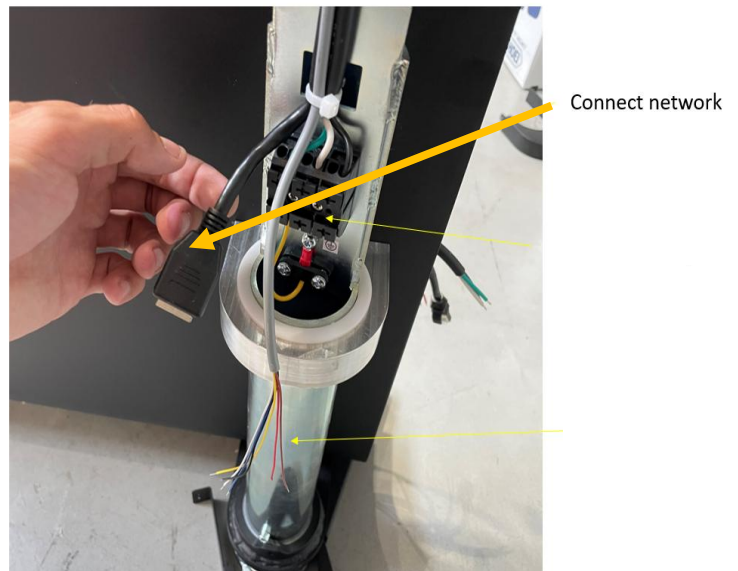

11. Adjustment of Gate PEC

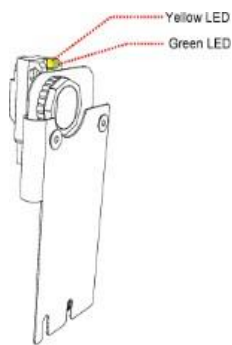
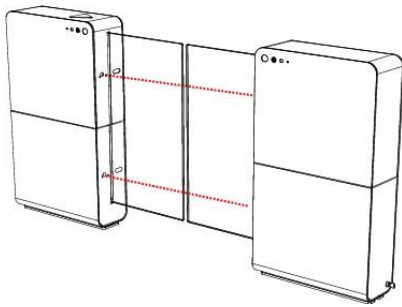

Make sure the two photoelectric cells (PEC) are pointing at the center of the reflectors on the other gate.

Adjust by using 2,5mm Allen keys through holes next to PEC sensor on outside of gate.

Step 1

Turn Allen key all the way LEFT until yellow connection light turns off.

Step 2

Turn Allen key all the way RIGHT until yellow connection light turns off, counting the amount of turns in between.

Step 3

Wind Allen key back to mid position.

EG. If it takes 6 full turns from left position to right position, then turn back 3 full turns.

IMPORTANT NOTE:

This must be done in both vertical and horizontal directions

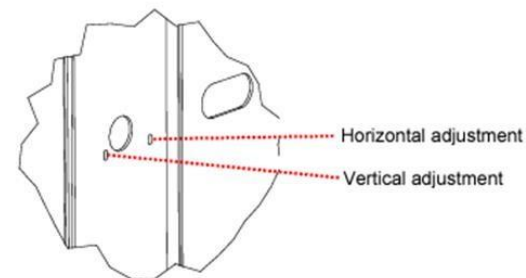
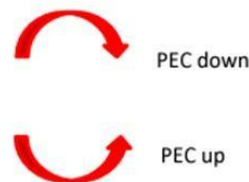
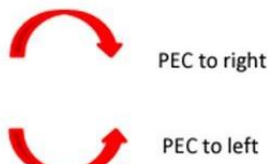

Note: The gates come with different PEC sensors installed. Some are yellow and others green. Each sensor has a sensitivity dial on the back. Please ensure the dial is adjusted as follows:

- **Green PEC sensors:** Turn the dial fully clockwise to maximum sensitivity.
- **Yellow PEC sensors:** Set the dial to 50% sensitivity.



PEC sensor sensitivity dial



12. Customer Facing Safety Radar installation

1. Find the SigmaGates and make sure you are installing the Safety radars as they are about to walk through the gates.



2. Open SigmaGates using the remote and then turn gate off by turning the key to the vertical position (only turns off the power to the motor) or cut the power to the gate.



3. Unlock Service hatch by using a flat head screwdriver to turn the lock into the vertical position.



4. Lift service hatch up and away from the SigmaGate.

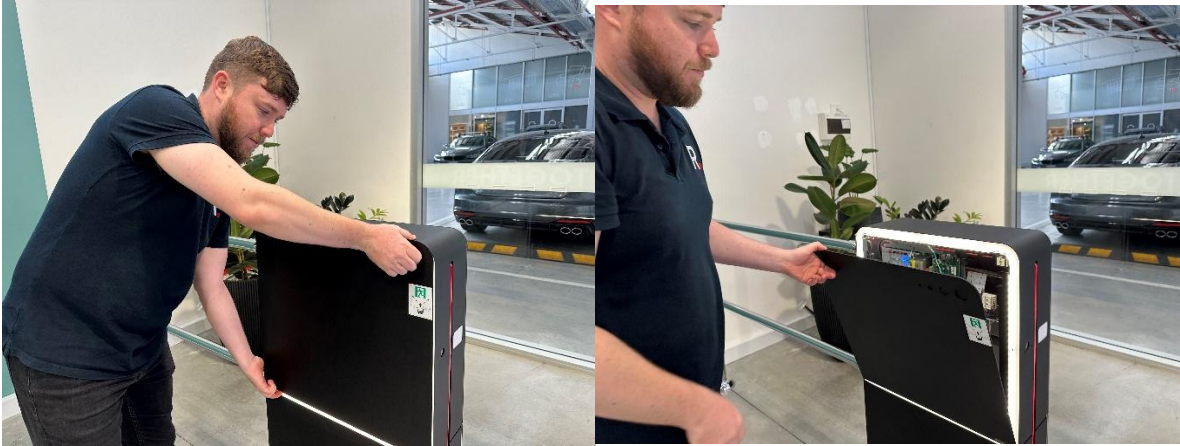

5. Disconnect the earth cable from service hatch.



6. Disconnect the power to the gate sides.

Note: Make sure you do not restart the ScanMaster or powering off and on the gate to often since this can damage the SD-card. Recommendation is to power off gates, leave them like that and power on again once installation is done and avoid restarting the ScanMaster using the button on the PCB.

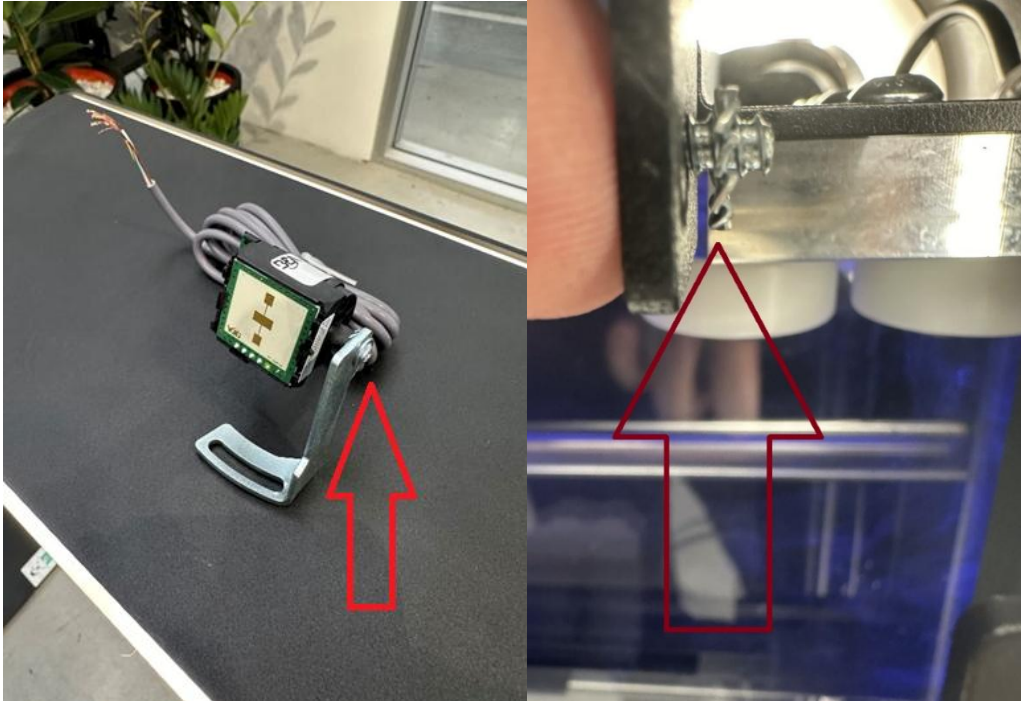

7. Remove the screw from the bracket and discard the bracket if supplied. Use the bracket screw and washer to mount the customer facing radar to in the corner of the SigmaGate with the washer between the mounting plate and radar **THIS IS IMPORTANT!** so that the radar does not slip after install.
8. It is also particularly important when tightening the screw that the radar is tilting downwards. This is to make sure that the radar picks up all customers.



Safety radar wiring

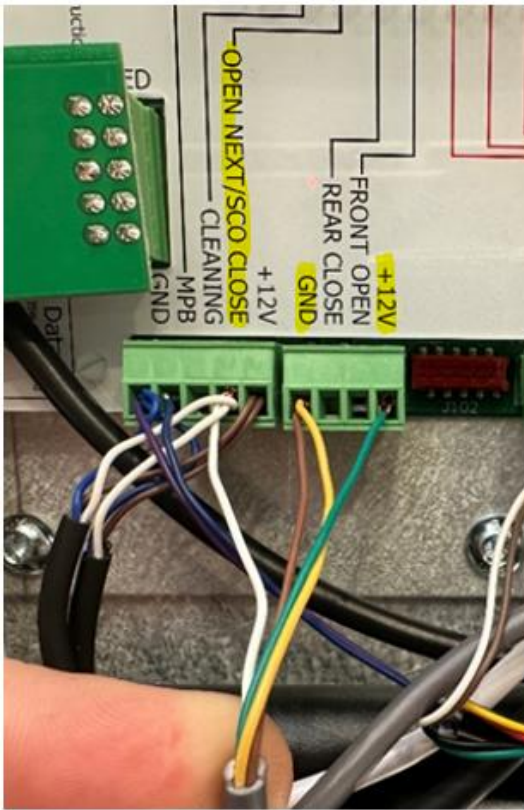

+12v = Green wire

GND = Brown and Yellow wires

OPEN NEXT/SXO CLOSE = White wire

9. Adjust the potentiometer on the side of the radar as shown in the image below left to set the detection range. The radars red LED will illuminate when a customer is detected as shown in the image below right.

Maximum sensitivity: Potentiometer turned all the way clockwise.

Minimum sensitivity: Potentiometer turned all way anticlockwise.

Note: The tuning of the radar will be the same no matter if it got the dial on the right or left side of the radar.

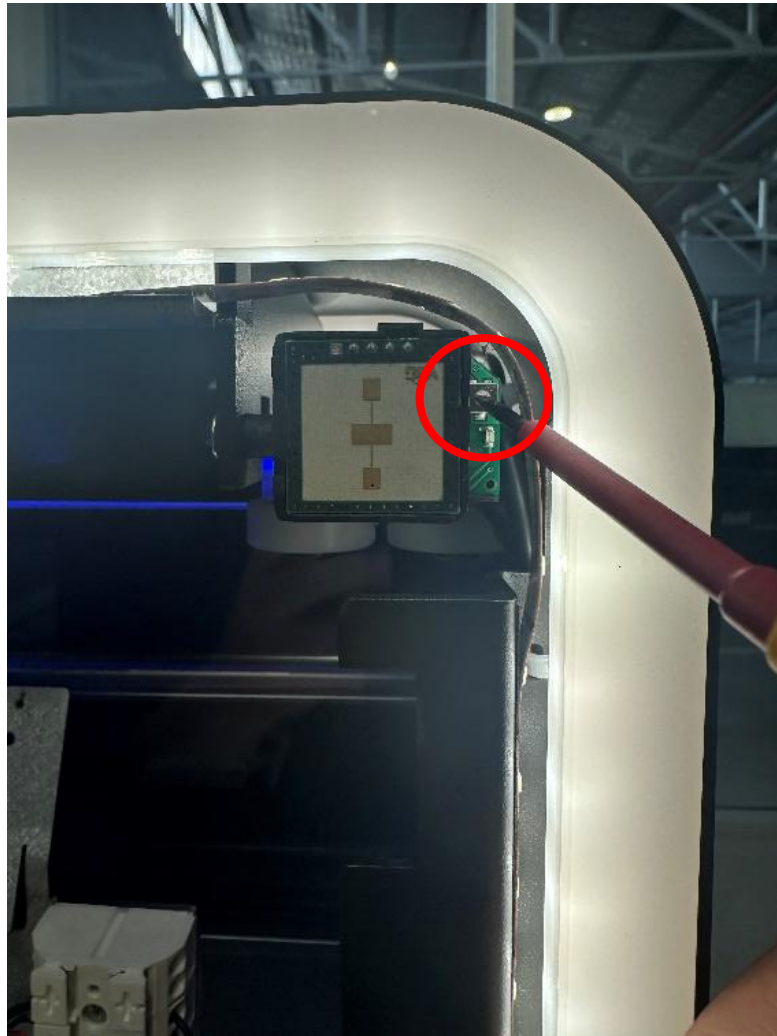

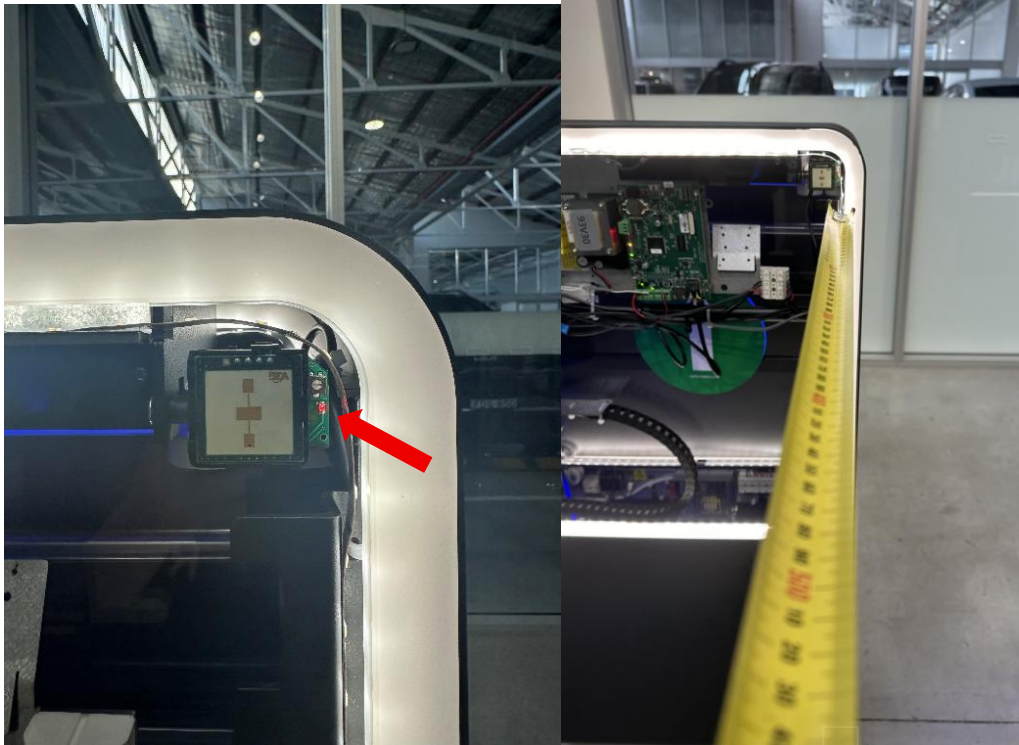

10. Set radar distance to **600mm** with the cover on using a measuring tape and the red LED indicator light to show that it is detecting customers.

Note: When evaluating the distance with the cover on the trigger distance will slightly decrease. Also make sure there is no checkouts opposite to the gate that might trigger the safety radars to trigger while closing.

11. Close up the SigmaGate by doing the inverse of the opening procedure.
 - Place service hatch on gate
 - Connect earth cable
 - Close service hatch
 - Close lock by using a flat head screwdriver turning it into the horizontal position
 - Power up the gate again.
 - Return gate functionality by using the remote.

13. Adjustment of Glass Door

If the glass doors need to be adjusted an adjustment screw (Allen screw M3) located on the lower section of the glass door can be adjusted (marked in red).

Before adjustment, three M6 nuts need to be loosened (marked in green).

Note: After adjustment, make sure to tighten the M6 nuts.

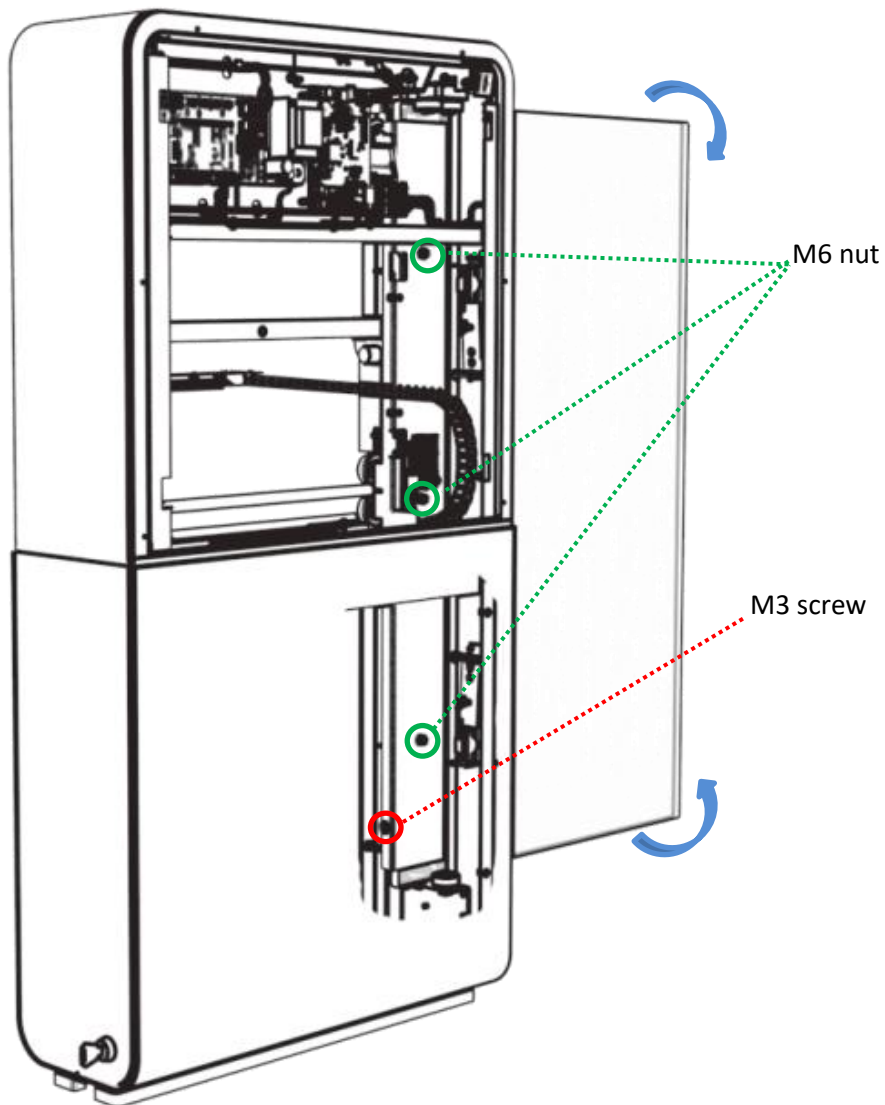

14. Configuration of ScanMaster 2.0

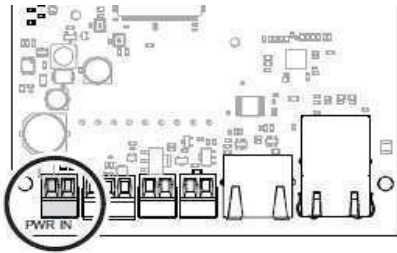

- 1 Disconnect the 12V power supply cable to cut the power.

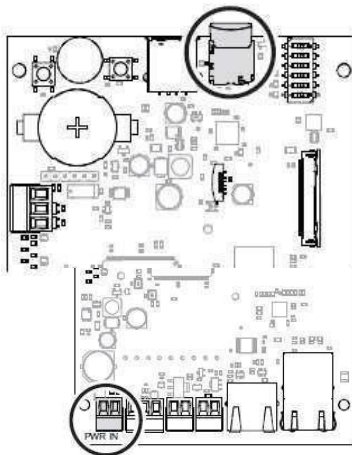

- 2 Put the Micro SD card for specific gate to the ScanMaster board.
Note: PLEASE CHECK THAT THE SDCARD IS THE CORRECT CARD FOR THE CORRECT GATE. Check against floor plan and IT Tracker.

- 3 Connect the 12V power supply cable.



- 4 The ScanMaster board will initialize over approximately 90 seconds. Once complete, the LED indicators should display as follows:

- LED 1 - Blinking green: Indicates normal operation.
- LED 5 - Single orange blink: Triggers once when a POS message is received
- LED 10 - Solid red: Indicates fault or error state.

15. DIP-switch settings ScanMaster

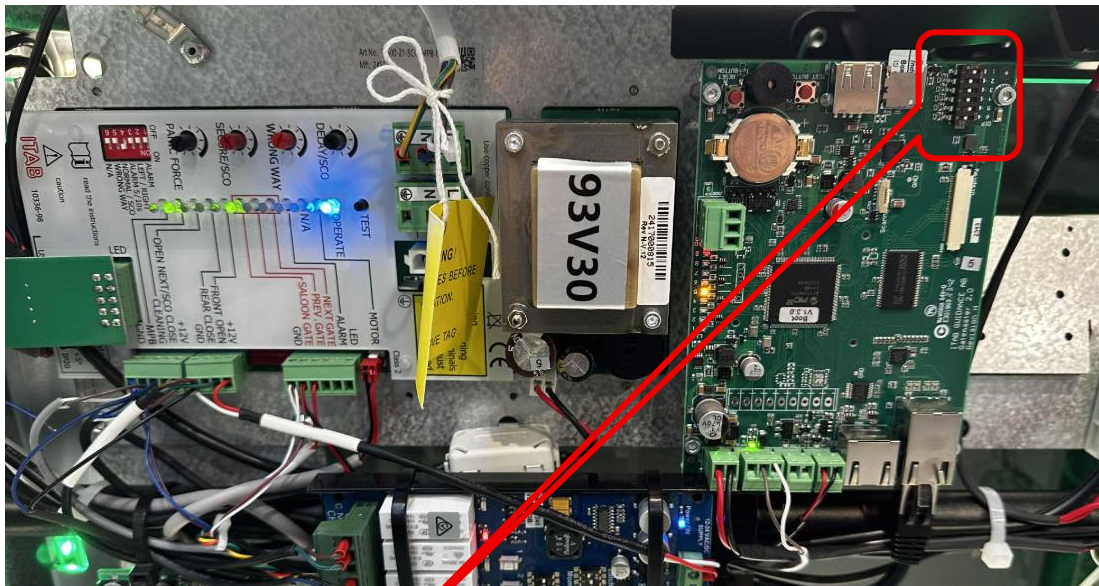

ScanMaster DIP-switches

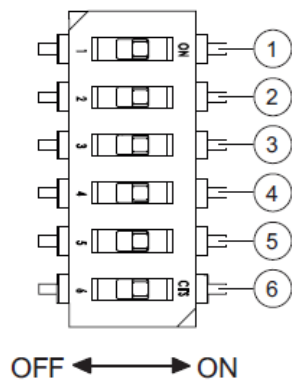

1. Buzzer on/off = **Right (ON)**
2. Ethernet required = **Right (ON)**
3. Service mode = **Left (OFF)**
4. Service IP (192.168.20.200) = **Left (OFF)**
5. GateCOM required = **Right (ON)**
6. Display on/off = **Left (OFF)**

16. Master & Slave Dip Switch Settings

The purpose of the Master and Slave function is to make it easier to set the timer functions on the main board. In a saloon configuration the right-hand gate (in the direction of the customers' travel) is ALWAYS the Master.



LEFT GATE

1. ALARM = Right (ON)
2. LEFT/RIGHT = Left (OFF)
3. ALARM 5/10s = Left (OFF)
4. NORMAL/SCO = Right (ON)
5. WRONG WAY = Left (OFF)



RIGHT GATE

1. ALARM = Right (ON)
2. LEFT/RIGHT = Right (ON)
3. ALARM 5/10s = Left (OFF)
4. NORMAL/SCO = Right (ON)
5. WRONG WAY = Left (OFF)

17. Master & Slave Potentiometer settings

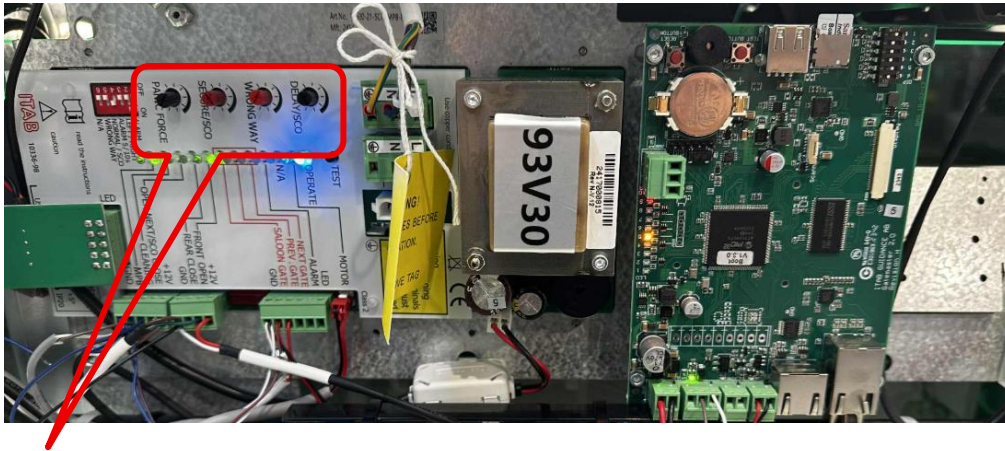

1.



DELAY: This sets the amount of time the gates will stay open after a customer has left through the gates and broken the PEC sensor beam. Range 0-8 seconds.

Note: This timer will override the securetimer.

2.



WRONG WAY: This timer is used to detect movement through the gates in the wrong direction. Please set to full right to avoid picking up a customer's swinging arm. Range 0.1-2 seconds

3.



SECURE: This timer will keep the gates open until the customer has passed through the gates. Once the customers pass through the gates this timer gets override by the DELAY timer. Range 0-30 seconds

4.



PANIC FORCE: This dial sets the force required to slide the glass arm back into the body of the SigmaGate

LEFT GATE (left gate when exiting through the gate)

1. Set DELAY, WRONG WAY, SECURE on the left-hand gate to maximum/clockwise. (100%)
2. Set PANIC FORCE to minimum/anticlockwise (0%)

RIGHT GATE (right gate when exiting through the gate)

1. Set DELAY to halfway. (50%) (4 seconds)
2. Set WRONG WAY to maximum/ fully clockwise. (100%) (2 Seconds)
3. Set SECURE to halfway. (50%) (15 Seconds)
4. Set PANIC FORCE to minimum/ fully anticlockwise. (0%)

Hint = turn all the way left (0%) then all the way right (100%) to work out where 50% is.

Note: For the Master and Slave function to be operational the gate configuration must be connected with GateCOM crossover cable (Saloon) to the opposing gate *See page 19.

19. Remote Installation (Gen 3 Remotes)

The following instructions will explain how to install a remote receiver inside a SigmaGate and how to set up the remote's functions if there is only one gate in the store controlled by the remote controls.

Note: The Generation 3 receiver does not include wiring. The installer will need to supply the necessary cables. To connect the receiver to the gate, you will need three 50 cm long 2-core wire cables.

Button 1 - will be programmed to activate 'Auto Close' on SCO Gate.







Button 2 - will not be used.

Button 3 – will not be used.

Button 4 –will be programmed to activate 'Cleaning Mode (permanent open mode)'.

Note: The remote-control receiver must be installed on the same gate side as the ScanMaster or the latched/cleaning signal will not be detected by the ScanMaster.

19.1. Wire the Receiver to SigmaGate Control Board

Receiver	SigmaGate Control Board (SCO Gate)
<p>Supply +</p> 	<p>12V</p>
<p>Supply -</p> 	<p>Ground</p>
<p>Ch1 NO</p> 	<p>Front Open</p>
<p>Ch1 C</p> 	<p>Ground</p>
<p>Ch4 NO</p> 	<p>Cleaning</p>
<p>Ch4 C</p> 	<p>Ground</p>

Connecting Power

1. Open the SigmaGate panel.
2. Connect **Supply +** to **12v** on the Sigma control board.
3. Connect **Supply -** to **Ground** on the Sigma control board.

Relay 1 (Auto-Close)

1. Connect **Ch1 NO** to **Front Open** on the Sigma control board.
2. Connect **Ch1 C** to **Ground** on the Sigma control board.

*Please note if the store, for example, has 3 pairs of gates and 3 receivers. Use relay 1 on the first pair. Relay 2 on the second pair. Relay 3 on the third pair.

Relay 4 (Latched/Cleaning Mode)

1. Connect **Ch4 NO** to **Cleaning** on the Sigma control board.
2. Connect **Ch4 C** to **Ground** on the Sigma control board.

*Please note that at a 3 gate store this will only be required for one receiver, otherwise all gates will be held open at the same time.

19.2. Mount the receiver

Note: The remote-control receiver must be installed on the same gate side as the ScanMaster or the latched/cleaning signal will not be detected by the ScanMaster.

Fit the receiver into the plastic bracket. Fit it into the trace.

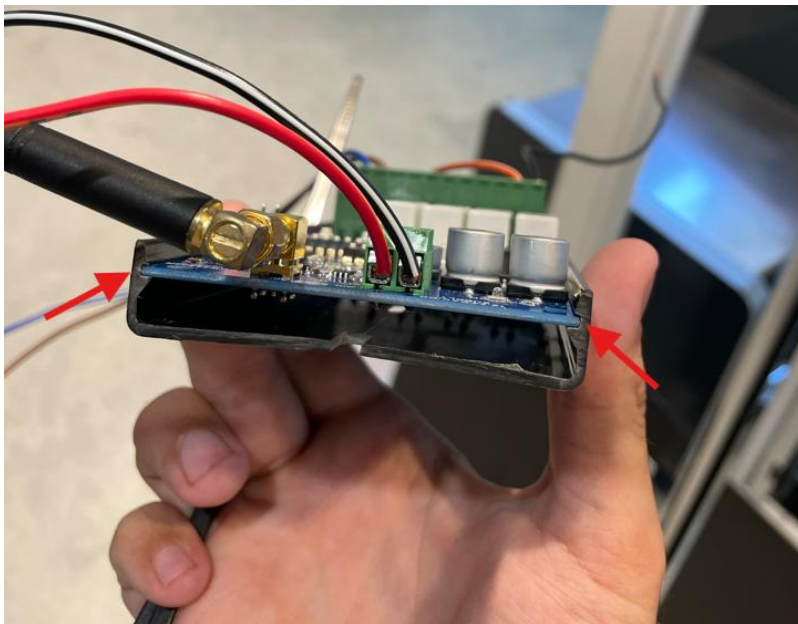

Remove cables from rail (creates extra space, otherwise the receiver can hit the cover when putting it back).

*Please note, if you don't have the plastic bracket, don't remove the cables. The cables will protect getting metal against metal.

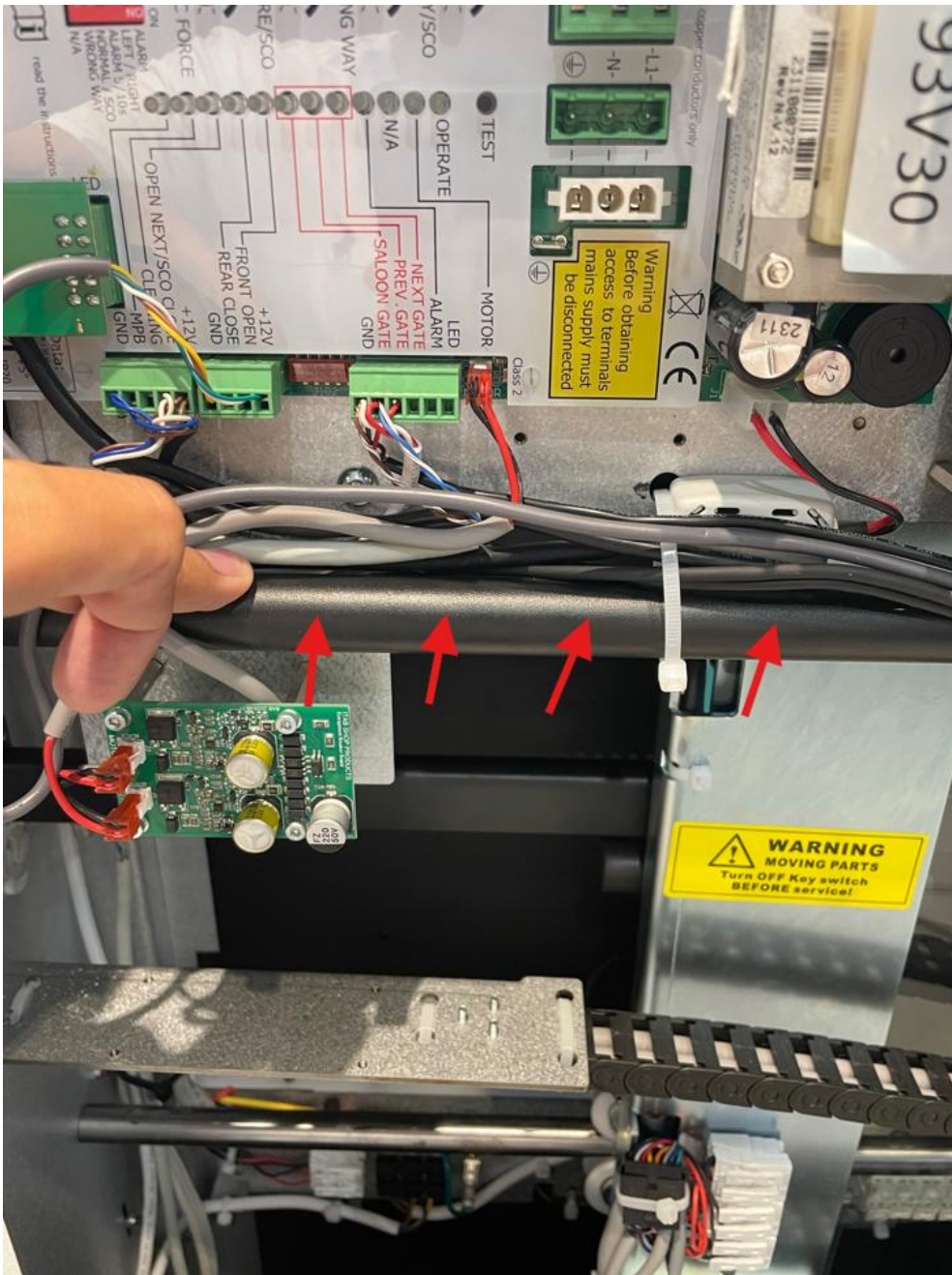

Let the bottom left corner "rest" on the screw to make it more stable (see second picture). Secure the receiver and cables with two cable ties (red arrows).

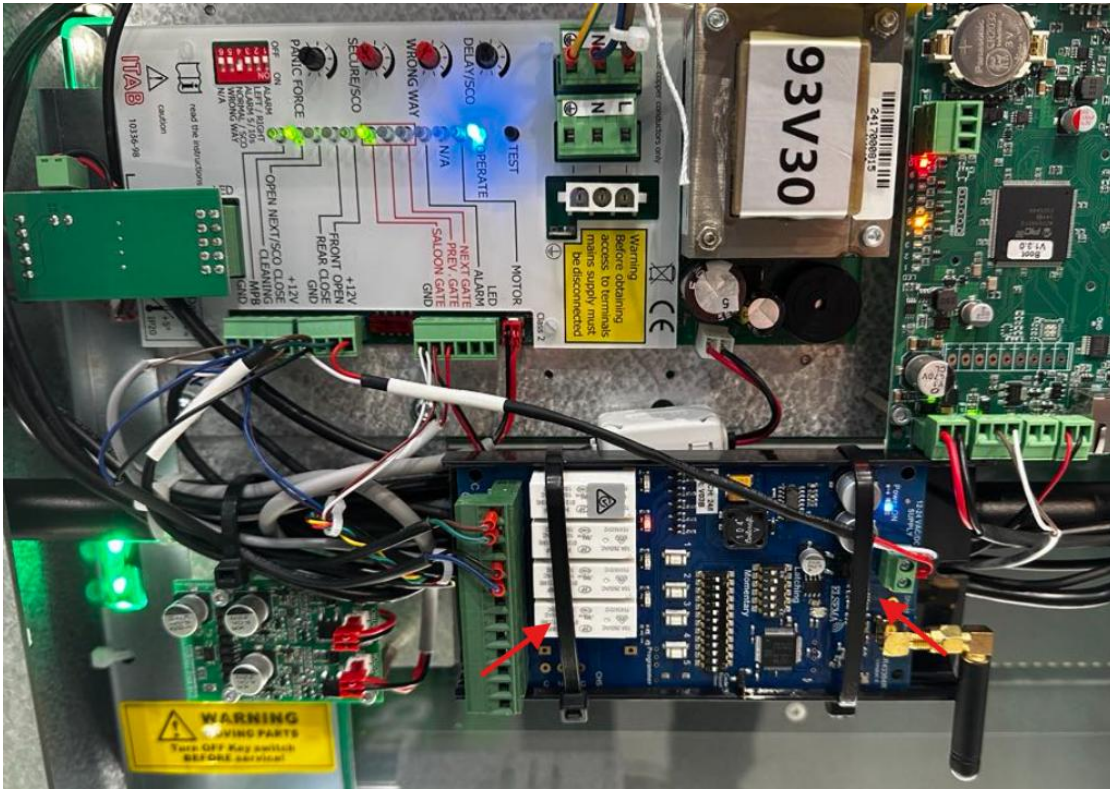

- The table below explains Dip switch 11 and 12. The first receiver should always have Off/Off. If you the store has two receivers. The first should have Off/Off and the second should have On/Off. Follow the table for all the different set ups.

	Receivers Dip Switch 11	Receiver Dip Switch 12
Receiver 1	Off	Off
Receiver 2	On	Off
Receiver 3	Off	On
Receiver 4	On	On

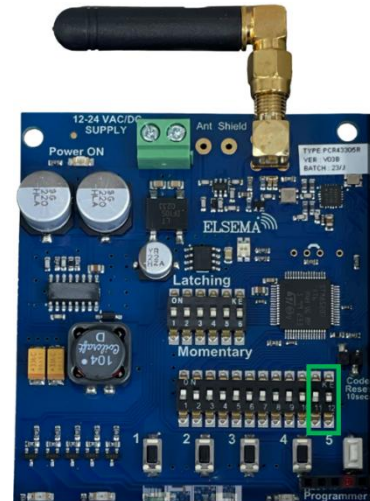

- Set Dip switches 1-10 in the remote exactly the same as the receiver. Dip switch 11 and 12 should always be Off/Off.



- Lastly, insert the battery and test the functions.



20. Remote monitoring cable

The purpose of the remote monitoring cable is to help the Sesame 2 software to monitor the use of the remote control for statistical purposes.

Please link two signal cables between cleaning and GND on the Gate control board and the middle port and the right port on the 3-pin connector on the ScanMaster 2.0 control board as shown below.

Note: The remote-control receiver must be installed on the same gate side as the ScanMaster or the latched/cleaning signal will not be detected by the ScanMaster.

Note: The Generation 3 receiver does not include wiring.

The installer will need to supply the necessary cables.

To connect the scanmaster DIN port to the Gate control board, you will need one 50 cm long 2-core wire cables.

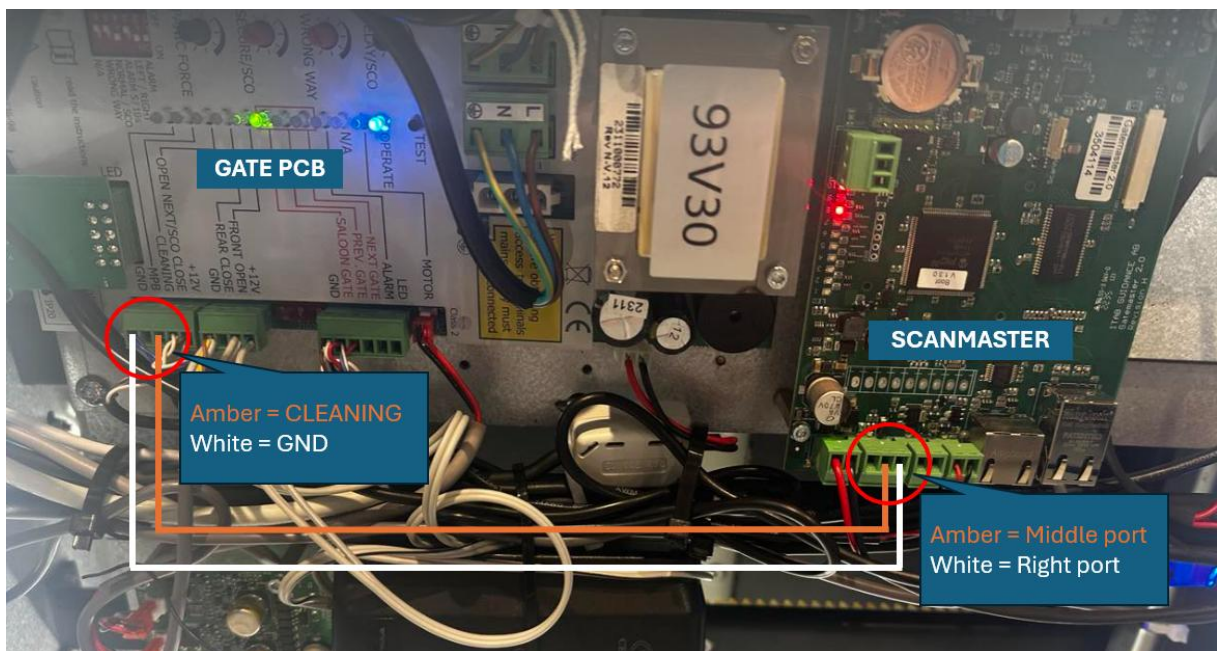

After connecting the signal cables between the ScanMaster and the Gate control board you need to verify that the ScanMaster board is picking up the latched/cleaning signal from the receiver/Gate control board. To do that you will first have to activate the latched/cleaning mode using one of the remotes. (Make sure the green LED light of the cleaning port is solid green on the GATE CONTROL BOARD. That means the latched/cleaning signal is active.

To know if the ScanMaster is picking up this signal, check the small LED above the middle port connector where the cable from the cleaning port is going into.

The LED should be solid green when latched/cleaning mode is activated and off when latched/cleaning mode is deactivated.

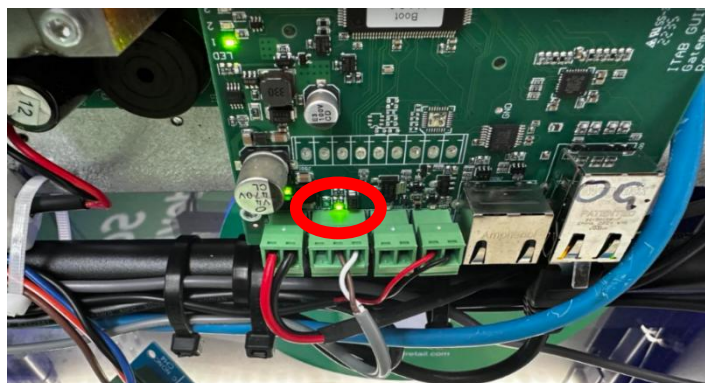

21. Commissioning sign-off checklist

Complete the following check list when installation is complete:	✓	✗
	Yes	No
Site manager to check that gates are fully operational by ticking the boxes and signing below:		
Pictures of the cables coming through the brackets measured at 1918mm.		
Picture of 6 Chemset threaded rods (m10) through the bracket.		
Picture of Chemset filled bolt holes in gate brackets.		
Picture of earth, power and neutral connected to terminal in middle of gate and in MPB bracket.		
Ensure the isolation switch is installed according to the instructions and that it cuts power to the gate when turned off.		
Pictures of 2core cross over cable connected to gate terminal in middle of gate and then connected to GND and saloon on gate control board with saloon LED illuminated.		
Picture of Ethernet connection into ScanMaster on master gate (right when you exit through the gate).		
Picture of gate PEC sensors are aligned. picture of both lights on (4 sensors per gate set) (2.5mm Allen key).		
Video showing the customer facing radars being triggered as the person approaches the gate from a distance of 600 mm.		
Picture of ScanMaster SD card installed into ScanMaster.		
Picture of ScanMaster DIP-switch settings.		
Picture of dipswitch settings on gate control board.		
Video of gates closing behind customers after 4 seconds.		
Video of gates being open when triggered for 15 seconds.		
Provide a video showing the gate activating when the test button on the Gatemaster is pressed.		
Video showing button 1 triggering auto-close and button 4 triggering latched/cleaning mode on the remotes.		
If there are additional gates in the zone, capture a video showing button 2 and 3 triggering auto close.		
Picture of remote monitoring cable connected to the gate control board and with the remote-control receiver connected to the same gate control board. (For all gates if multiple)		
Video of the small green LED light of the ScanMaster being solid green while the remote control triggered the gate to latched/cleaning mode. (For all gates if multiple)		
Picture of gate body clear of debris (no excess cables, no cable ties etc.).		
Fluke test results.		
Gates are to be left keyed off and remotes are to be handed to the store manager and declaration signed.		
Ensure all 4 PEC sensor glasses are cleaned on all installed gates post installation.		
Ensure there is no dirt or fingerprints on the ceiling mounted sensors post installation.		
Add gate serial number. Gate 1: _____ Gate 2: _____		
Are you satisfied that the finished works are compliant , and the layout is suitable to perform its intended operations?		
Are there groundwork fixings follow up required?		
Are there any screws or rubber/plastic bungs needing replacing ?		
Are there any covers needing replacement ?		
Are there any keys needed to be supplied to the store?		
Is there any equipment left behind for Coles perusal (if yes please was the store manager notified of location)?		

22. Store manager declaration

Coles sign-off document	
Store name:	
Store address:	
Store number:	
Store manager's name:	
Store manager's signature:	
Date:	
Contractor company name:	
Technicians' name:	
Technicians' signature:	
Date:	
Please make notes of any follow-up work required below	

23. Troubleshooting Schedule

Please read through the following steps:

Gates do not open:

- Check that there is power to the gate.
- Check the motor key switch is turned ON.
- Check if the gates are being held open on the remote controls.
- Check that the data cable is plugged into the ScanMaster 2.0
- Check the connections of GateCOM cross over cable.

Gates do not close:

- Check that the motor key switch is turned ON.
- Check that PERMANENTLY OPEN MODE is not activated by checking for illuminated LED on main PCB
- Check that the photoelectric cells are pointing directly at the corresponding reflector. See page 22 for adjustment of PEC.
- If the gates are equipped with Mechanical Panic Breakout, check that the gates are in normal position.
- If the problem is still not solved, switch off the mains power to the gate and turn it back on.

The gate alarm is activated:

- Check that the motor key switch is turned ON.
- Check that the photoelectric cells are pointing directly at the corresponding reflex. See page 22 for adjustment of PEC.

The gates do not behave as intended:

- Check the configuration of the gates concerning MASTER & SLAVE on page 33.
- Check that the photoelectric cells are pointing directly at the corresponding reflex.
- If problems continue, contact Radford Support.

For more installation & troubleshooting guides, please visit our knowledge base here:

<https://radfordretail.zendesk.com/hc/en-au>