

SigmaGate & Sesame 2

EXIT SOLUTION

Coles SigmaGate & Sesame 2 - Installation Manual

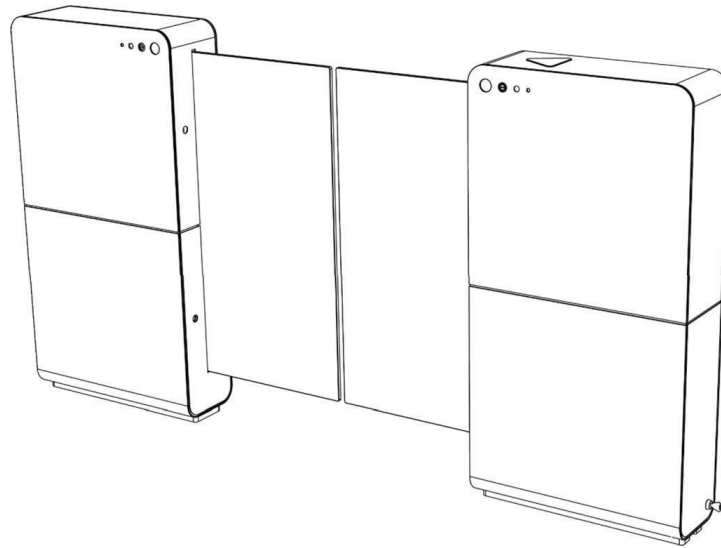

Version control

Version	Date	Comments	Issued by
7.2	N/A	First version	Radford
7.3	2025-01-21	Added updated details from the general SigmaGate manual	Jonathan Gunnarsson
7.4	2025-01-22	Updated Receiver/remote instructions (Generation 2)	Jonathan Gunnarsson
7.5	2025-01-23	Added commissioning sign-off checklist	Jonathan Gunnarsson
7.6	2025-02-14	Clarified a few steps in the remote-control installation section.	Jonathan Gunnarsson
7.7	2025-03-14	Removed receiver/remote gen2 and added gen3.	Alexander Johansson
7.8	2025-07-02	Added notes about wiring not included with remote receiver.	Jonathan Gunnarsson
8.0	2025-12-11	Sections for isolation switch, split junction box, explaining pictures and a link to MPB 2.0 have been added.	Alexander Johansson

Table of Contents

1.	Sesame 2/SigmaGate system introduction	4
2.	Contact Information	5
3.	Shipment Content with MPB	5
4.	Install drop down poles	6
5.	Install data cables to sensors	7
6.	Install the Store tacker (and Spider device if needed)	8
7.	Unpack SigmaGate with MPB	9
8.	SigmaGate Dimensions with MPB function (EXIT)	10
9.	Routing of cables through the floor	11
10.	Mounting of a SigmaGate with MPB.....	12
10.1.	Important notes on floor assessment for SigmaGates.....	12
10.2.	Step-by-Step Instructions	13
10.3.	Shims and base plate lifter	14
11.	Securing MPB bracket into position.....	15
12.	Routing of Power and Data cables through MPB.....	15
13.	Connection of Power (MPB from floor)	16
14.	Connection of Power to SigmaGate (only if the gate does not have the MPB bracket).....	17
15.	SigmaGate isolation switch installation	18
16.	Connection of GateCOM/Crossover cable/Saloon Cable through MPB junction box	19
17.	Install split junction box cover	20
18.	Connection of Ethernet	21
19.	Adjustment of Gate PEC	22
20.	Customer Facing Safety Radar installation	23
21.	Adjustment of Glass Door.....	30
22.	Configuration of ScanMaster 2.0	31
23.	DIP-switch settings ScanMaster.....	32
24.	Master & Slave Dip Switch Settings	33
25.	Master & Slave Potentiometer settings.....	34
26.	Check the gate timing using the ScanMaster board	35
27.	Remote Installation (Gen 3 Remotes).....	36
27.1.	Wire the Receiver to SigmaGate Control Board.....	37
27.2.	Mount the receiver.....	38
27.3.	Set the DIP Switches & Pair Remotes	41
28.	Remote monitoring cable	43
29.	Commissioning sign-off checklist.....	44
30.	Store manager declaration	45
31.	Troubleshooting Schedule.....	46

1. Sesame 2/SigmaGate system introduction

The ITAB Sesame 2/Sigma system is a unique system fully developed by Itab AB Sweden that incorporates patented software.

Sesame 2 is designed to identify the customer who has fully completed payment for the purchase of goods at the checkout POS terminal.

This payment confirmation was achieved via a series of overhead camera sensors (loaded with Itab IP software) profiling the people standing next to the payment terminal at the same moment their payment has been validated through the same checkout payment terminal.

Upon validation by the store POS payment terminal a signal is instantaneously sent to a device (usually installed at the back end of the store) known as a storetracker (also loaded with Itab IP software) and validates a customer using the overhead mounted camera sensors.

At the physically controlled exit point, a set of SigmaGates are installed to create a physical barrier to non-paid customers and only opening for the paid and validated customer as they approach a pre-set distance to the SigmaGate.

After the paid customer passes through the gates, they return to their normally closed position thereafter awaiting the next paid customer to approach.

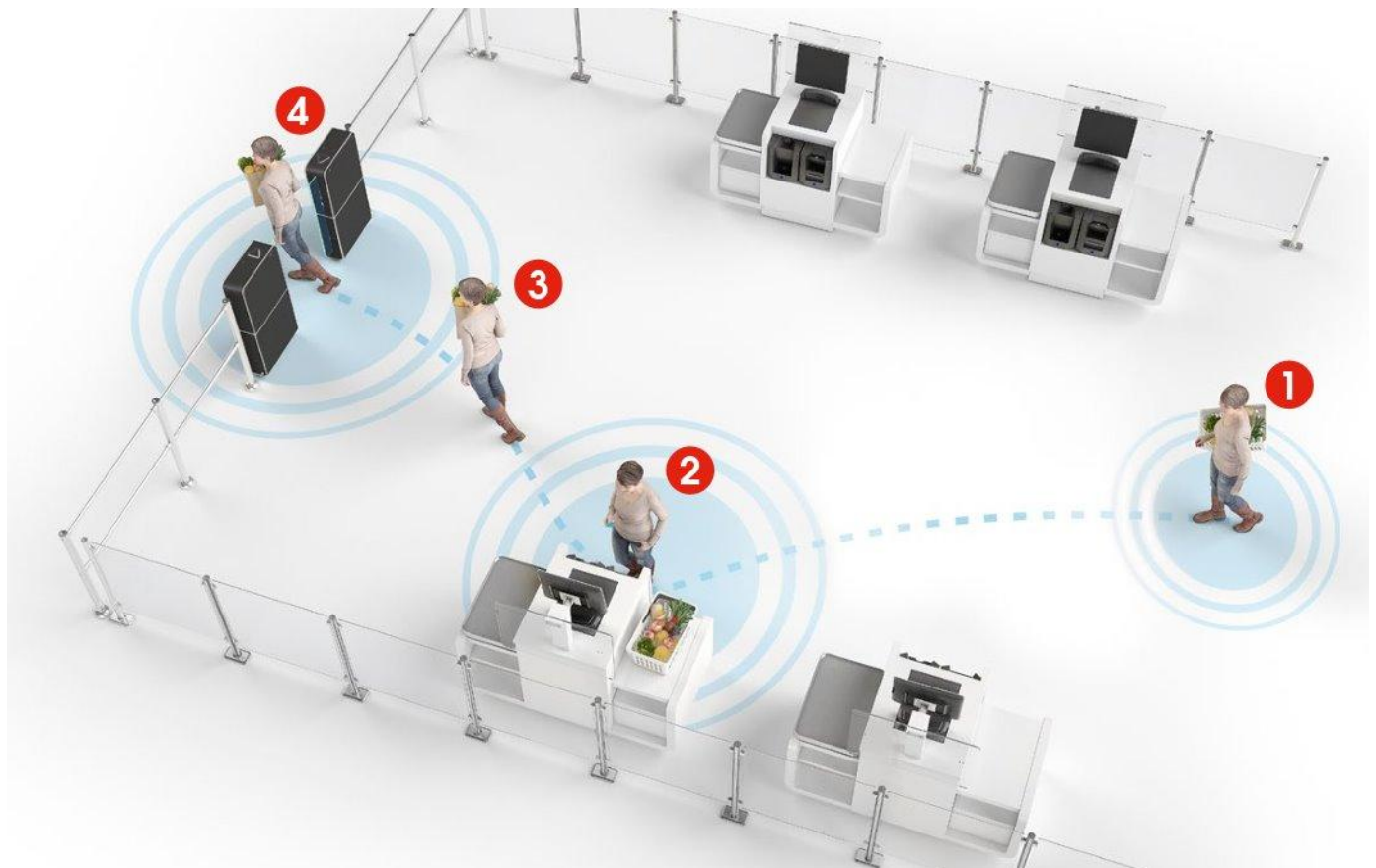

2. Contact Information

Shipping address: Unit 6/ 5-7 Malta St Fairfield East

Software support – support@radfordretail.com

Service – service@radfordretail.com

Knowledge base - <https://radfordretail.zendesk.com/hc/en-au>

3. Shipment Content with MPB

Note

Make sure that the following content is delivered before starting installation. Below content is based on a saloon installation of SigmaGates. Keys are attached with cable ties behind the service hatch.

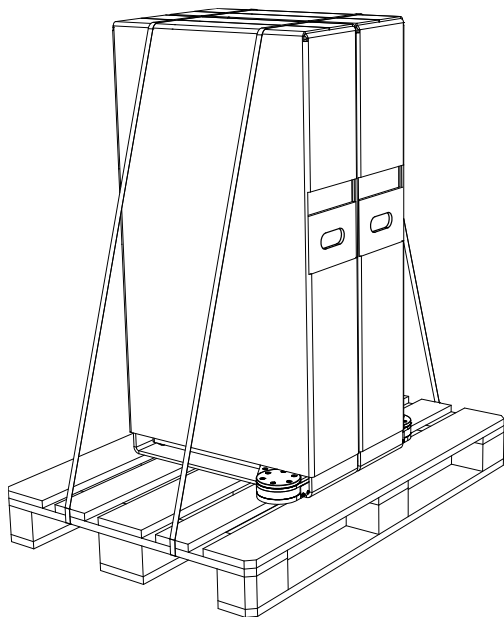

- SigmaGate MPB
- Base plate lifter kit
- Forth fixing
- Split junction box
- Drilling template

If the gates have the new MPB 2.0, the link below will provide an additional manual. [MPB 2.0 - Installation Manual](#).

4. Install drop down poles

To install the SigmaGate/Sesame 2 system into the front-end self-scan area (or conventional checkout area) please follow the below steps:

Install drop down poles and mount camera sensors, precisely as located from store drawing – store drawing to be provided by the builder.

Important notes on installing Xovis sensors onto the drop-down poles:

- a) Must be installed as per matching ID as each sensor will have its own IP address and location above the floor – check with to ensure the correct Xovis sensor match the overhead floor location.
- b) Must be installed at a specific height.
- c) Must be Installed Level.
- d) Must be installed rigidly to prevent movement.
- e) Must be installed as per individual store drawing – check with builder as dimensions (floor location & height from floor) are critical and will vary from site to site.
- f) Must be kept free from dust and grease.

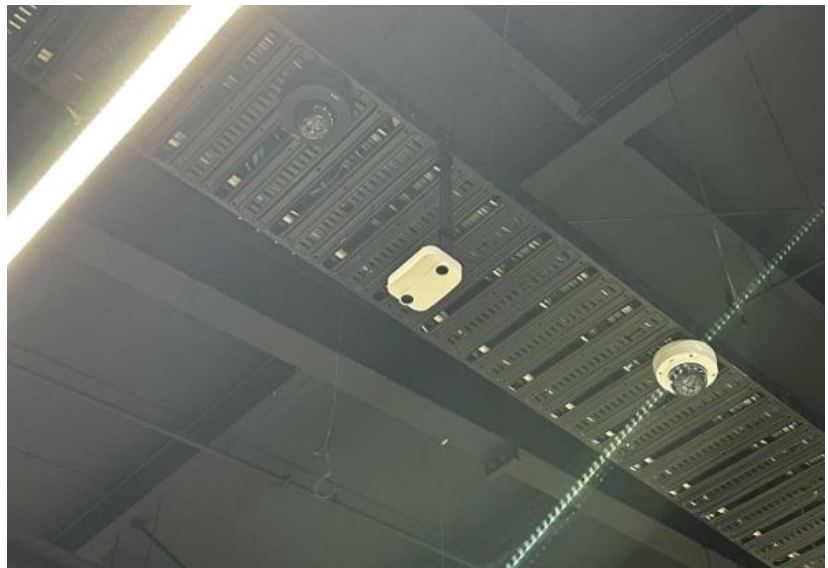

5. Install data cables to sensors

Install data cables (cat7 or higher are recommended) as plug & play cables to each Xovis sensor and spider (if required) to Coles network (Xovis sensors front-end coms cabinet and spider (if included) the Coles network via the backend coms cabinet.

Note: If more than nine Xovis sensors are used, an additional device (spider) will also have to be connected to the network. See drawing below showing a typical schematic of the sesame 2 hardware.

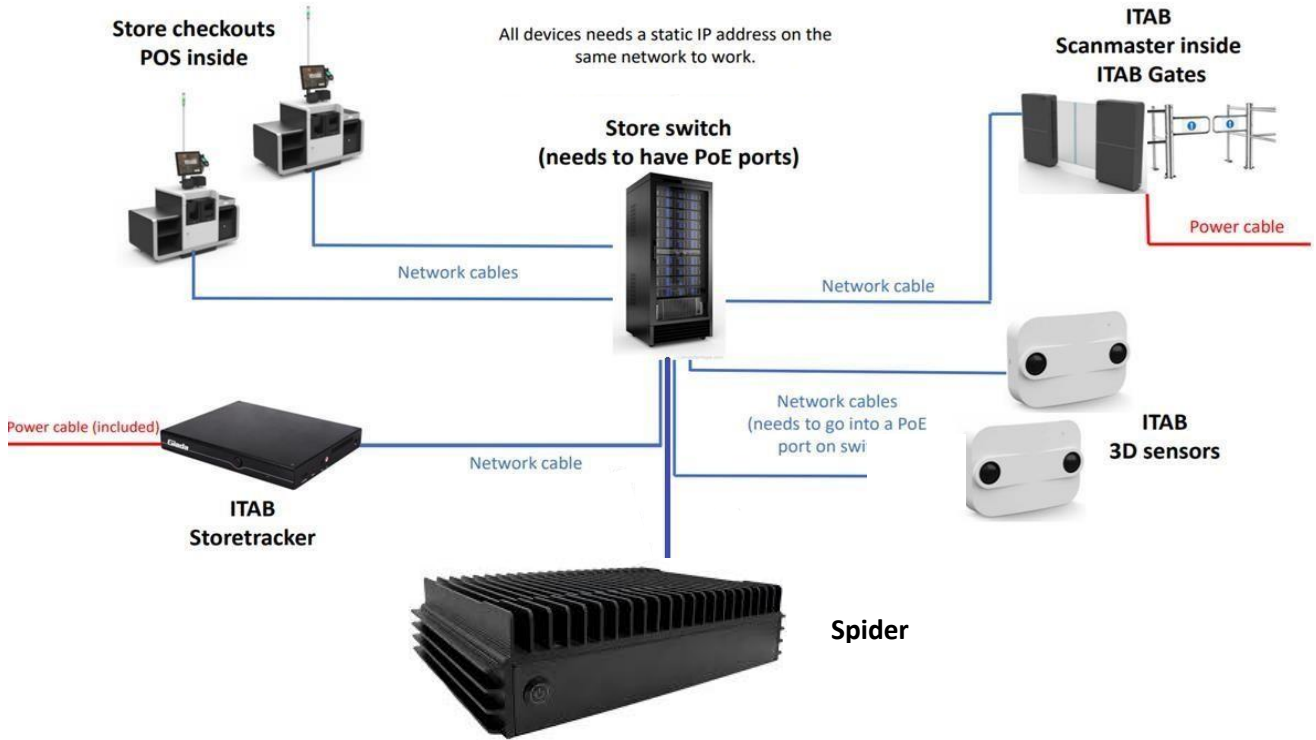

Note: Store checkouts and POS systems are already connected to the store switch, and it is not necessary/required to run additional patch leads to the checkouts.

6. Install the Store tacker (and Spider device if needed)

Store trackers and Spider devices are to be placed in the comms cabinet (see site manager for cabinet number) and be plugged into a 240-power outlet using the power cables provided.

Connect store tracker and Spider to the switch using a cat7 or higher network cable. Plug one end of network cable into the programmed port (the one with the IP address next to it) and the other end of the network cable into the designated port in the comms cabinet. See IP tracker for port number.



Please note that a spider is only needed if more than nine sensors are being used in the same zone.

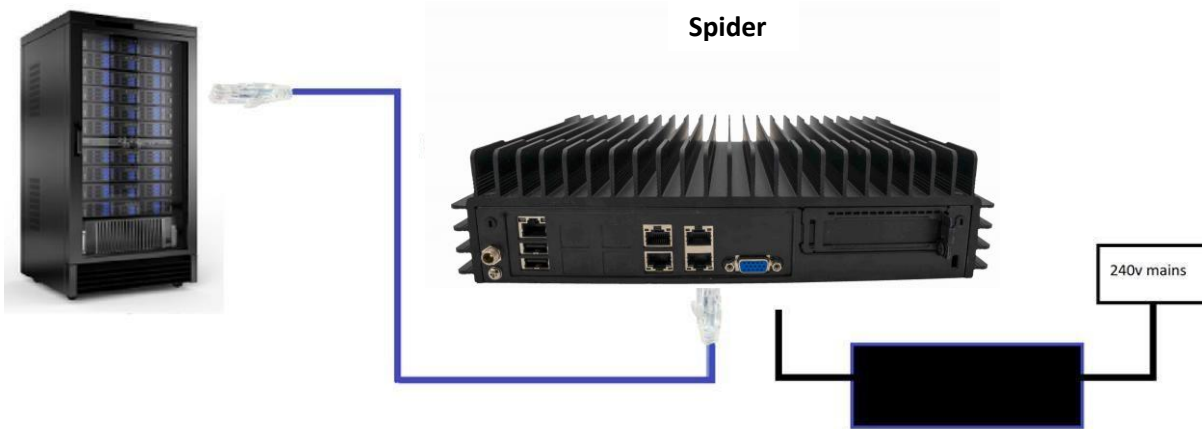

7. Unpack SigmaGate with MPB

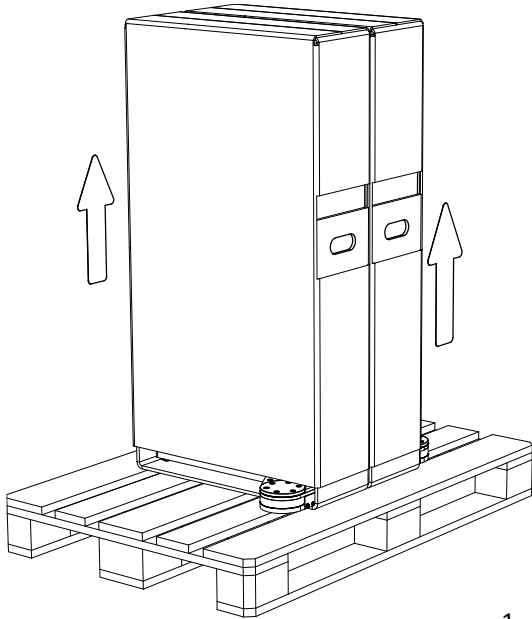

⚠ WARNING

The SigmaGate are heavy. Be careful and don't lift it higher than necessary for removing it from the pallet.

1. Use the handles to remove the SigmaGates from the pallet.

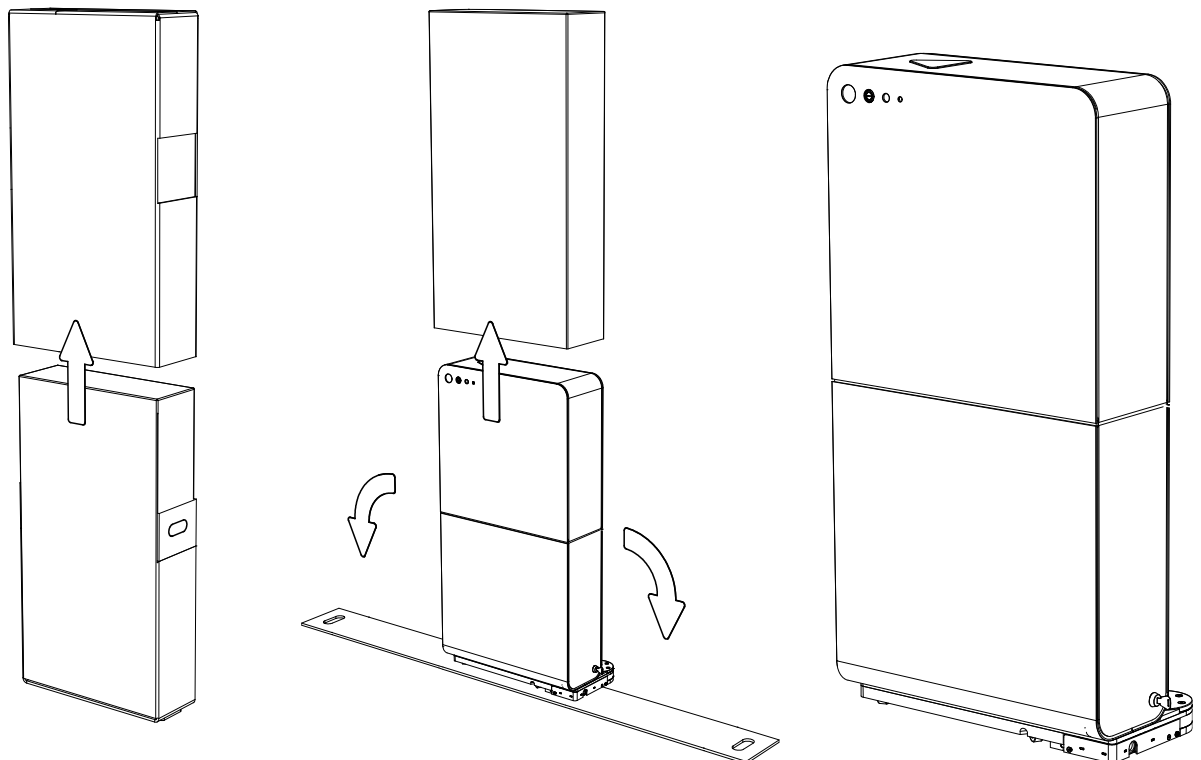

2. Lift the packaging and remove the SigmaGate.

9. Routing of cables through the floor

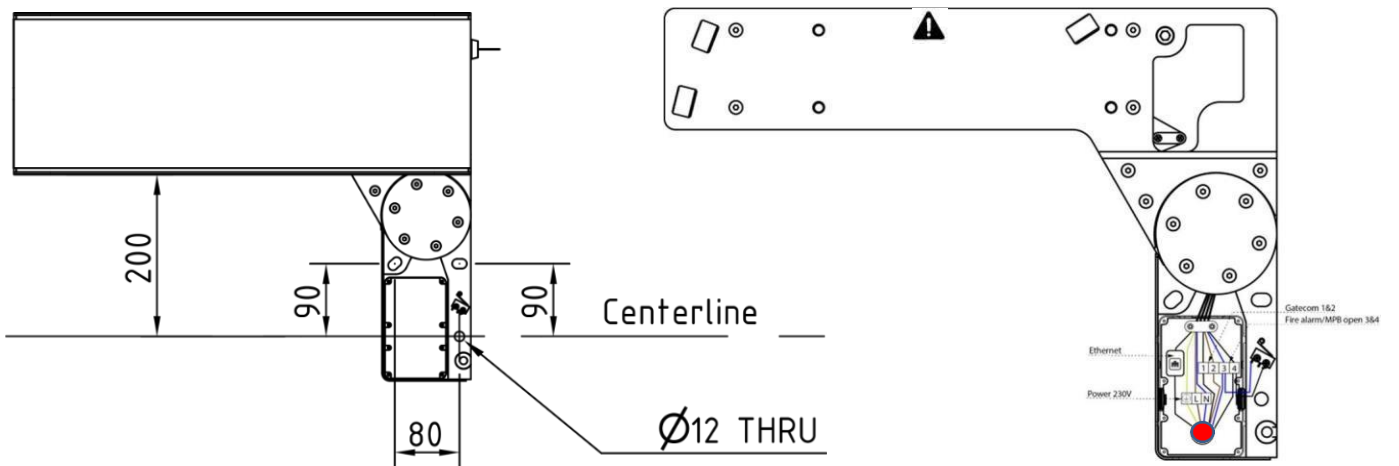
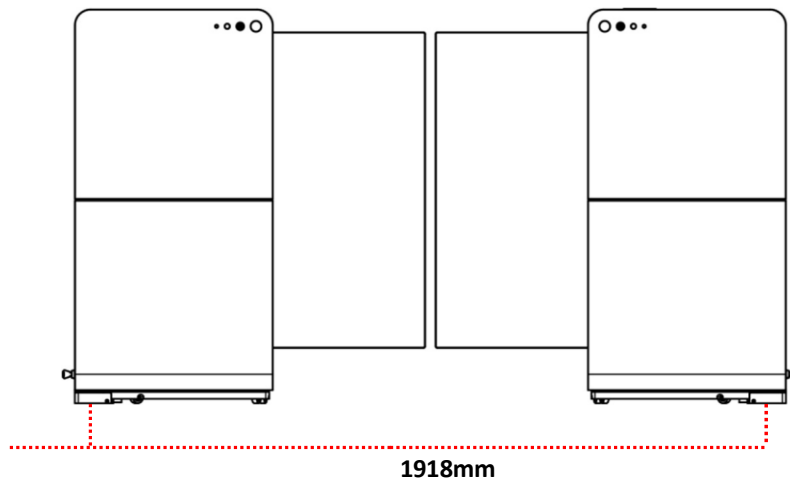
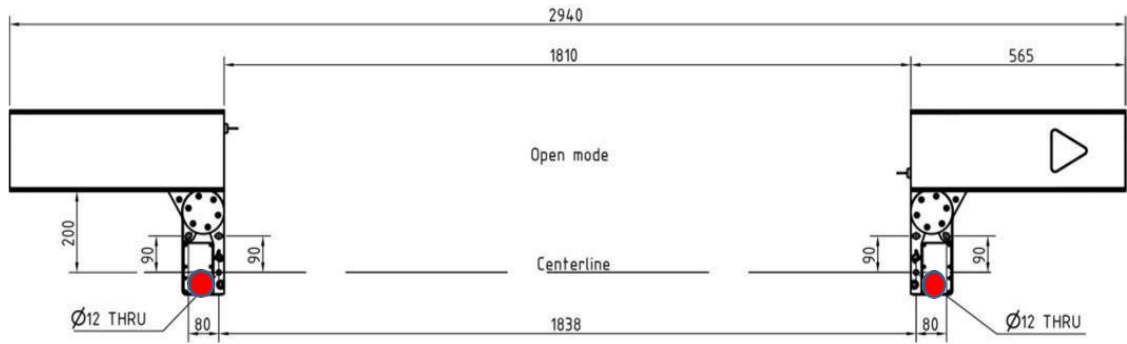

10. Mounting of a SigmaGate with MPB

10.1. Important notes on floor assessment for SigmaGates

Pre-Installation Checks

1. **Check floor level**

Before drilling any fixing holes, confirm that the ground is level. A maximum floor bowing of **10 mm** can be accommodated by using the **Base Plate Lifter** supplied in the kit.

2. **Gate alignment**

If a Base Plate Lifter is required, it will usually be needed on **both gate boxes**. Installing it on only one side may cause the gate arms to sit at different heights.

3. **Mark the gate arc**

Mark out the full opening arc of the gate, approximately **1000 mm at 90 degrees** from the centre of the MPB bracket. This establishes the breakout area of each gate box. Confirm that the floor within this arc is flat and level. Fit Base Plate Lifters as needed.

4. **Final fixing hole**

The **fourth (front, smaller) fixing hole** must be drilled precisely.

- Drill through the Manual Pushout Bracket hole to ensure accuracy.
- This hole should be drilled **only after the three main fixings are fully installed** with the SigmaGates correctly aligned and locked into the floor with Chemset.
- This sequence provides the best chance of maintaining long-term alignment.
- *Tip:* Start with a slightly smaller drill bit, then re-drill with the precise size required.

Disclaimer

The decision on whether a Base Plate Lifter is required lies solely with the installer.

A Base Plate Lifter is needed if:

- An uneven floor prevents the gate breakout function from opening fully.
- Floor unevenness puts excessive pressure on the wheel, leaving significant marks on the floor.

Important: If a Base Plate Lifter is used, the **cable penetration point** from the floor may need to be adjusted.

Base Plate Lifter Kit Contents

- 2 × sets of 1 mm retrofit base plates
- 2 × sets of 3 mm retrofit base plates
- 2 × sets of circular shims for brackets
- 1 × left MPB “L” corner bracket
- 1 × right MPB “L” corner bracket

Additional Notes

1. If a lifting bracket may be required, ensure **sufficient thread length remains** for bolting the gates onto the fixings.
2. For return site visits, assess whether using this kit will require **relocating the gate** due to insufficient thread left on the existing floor fixings.
3. The floor beneath the gates must be **tiled and structurally sound**.
4. When using lifter plates, always start with the **smallest thickness** and reassess before fitting a thicker plate.

10.2. Step-by-Step Instructions

1. **Position and mark fixings**
 - Lay out the SigmaGate using the **floor drilling template** provided.
 - Mark the positions for the three main ground fixings.
 - Mark the **power and data apertures** for floor chasing, including the cross-over data cables, before drilling.
 - **Note: Each SigmaGate unit requires a 240V power supply chase.**
2. **Mark the centerline**
 - Mark out the centerline along which the gates will be installed.
3. **Mark perpendicular lines**
 - From the centerline, mark two perpendicular lines **1838 mm c/c**.
 - Ensure these lines are centered on the entrance or exit opening.
4. **Mark drilling holes**
 - Using the drilling templates, mark out the six required drilling holes.
5. **Drill holes**
 - Drill the fixing holes, ensuring that they are **no larger than Ø10 mm**.
6. **Check floor flatness**
 - Confirm that the floor is flat.
 - If uneven, use the **supplied shims** to correct the level before proceeding.
7. **Fix brackets**
 - Secure the mounting brackets to the floor using **appropriate fasteners**.
 - The manufacturer recommends **chemical fixings** for maximum stability.
 - **Note: Final responsibility for the choice of fasteners and fixings lies with the builder or architect.**

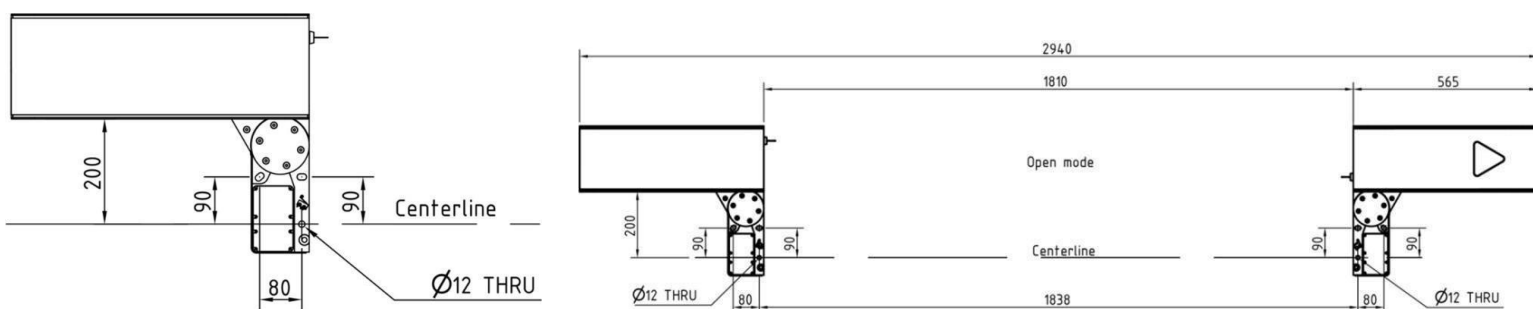
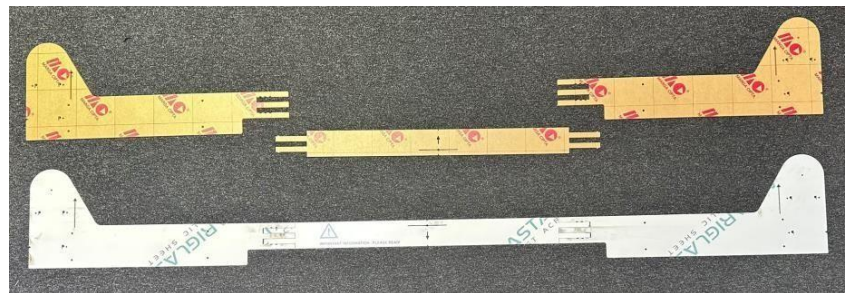

10.3. Shims and base plate lifter

Please note that the inclusion of shims is part of the BOM which can be used to pickup any play within the MPB swivel assembly.



11. Securing MPB bracket into position

Note: It is very important to ensure base plates sits above floor tile level.

Two of the four holes for fastening the MPB block to the floor are made larger to allow adjustment when installing the gates. If the fasteners are not holding the MPB block strong enough to the floor, the gate position can be incorrect leading to interrupted photocell signals and faulty behaviour of the gates. To prevent this, the two larger holes can be filled with chemical anchoring to lock the position after making sure the gates are in line with each other.

Use countersunk concrete screw supplied for the fourth fixing.

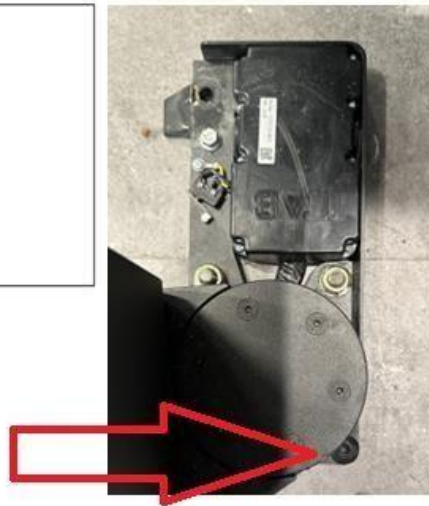
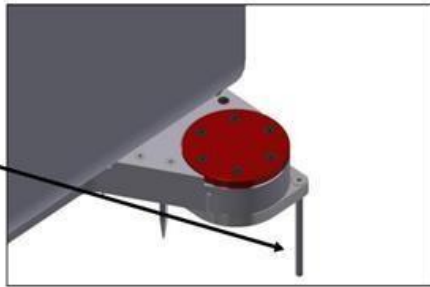

12. Routing of Power and Data cables through MPB

There are two ways of routing Power and Data cables into SigmaGate MPB.

1. Through the floor. Holes for the cables need to be drilled in the floor and cables can be routed through the MPB base plates.
2. Through uprights and ceiling feeding tubes. Cables are then routed via a short chase along the floor and then through the MPB base plates.

Note: Power feed cable to be reticulated from an approved isolator.

Note: The MPB is designed for use in the event of system malfunctions or emergencies and is not intended for stock feed purposes or any other similar activities.

13. Connection of Power (MPB from floor)

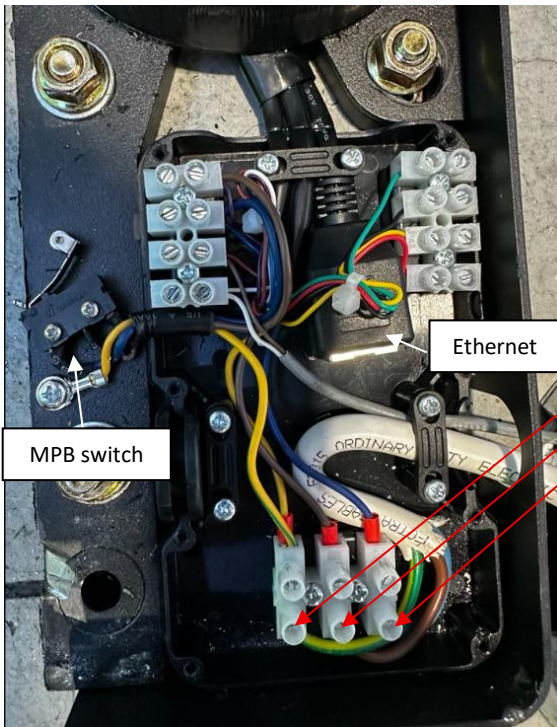

- Connect earth, live/phase and neutral cables to the connection terminal according to the markings on the terminal.
- Do not remove gate stop from bracket or the microswitch may become damaged.

- Connect green/yellow cable (Earth) to  socket.
- Connect brown cable (Live) to L socket.
- Connect blue cable (Neutral) to N socket.

14. Connection of Power to SigmaGate (only if the gate does not have the MPB bracket)

1. Pull the 230V cable through the cable ties in the lower corner of the gate. Tighten the cable ties.
2. Do not store any excess cables or ties inside the gate.
3. Adjust the cable length.
4. Connect earth, phase and neutral cables to the connection terminal according to the markings on the terminal.
5. Fasten the cable to the strain relief.

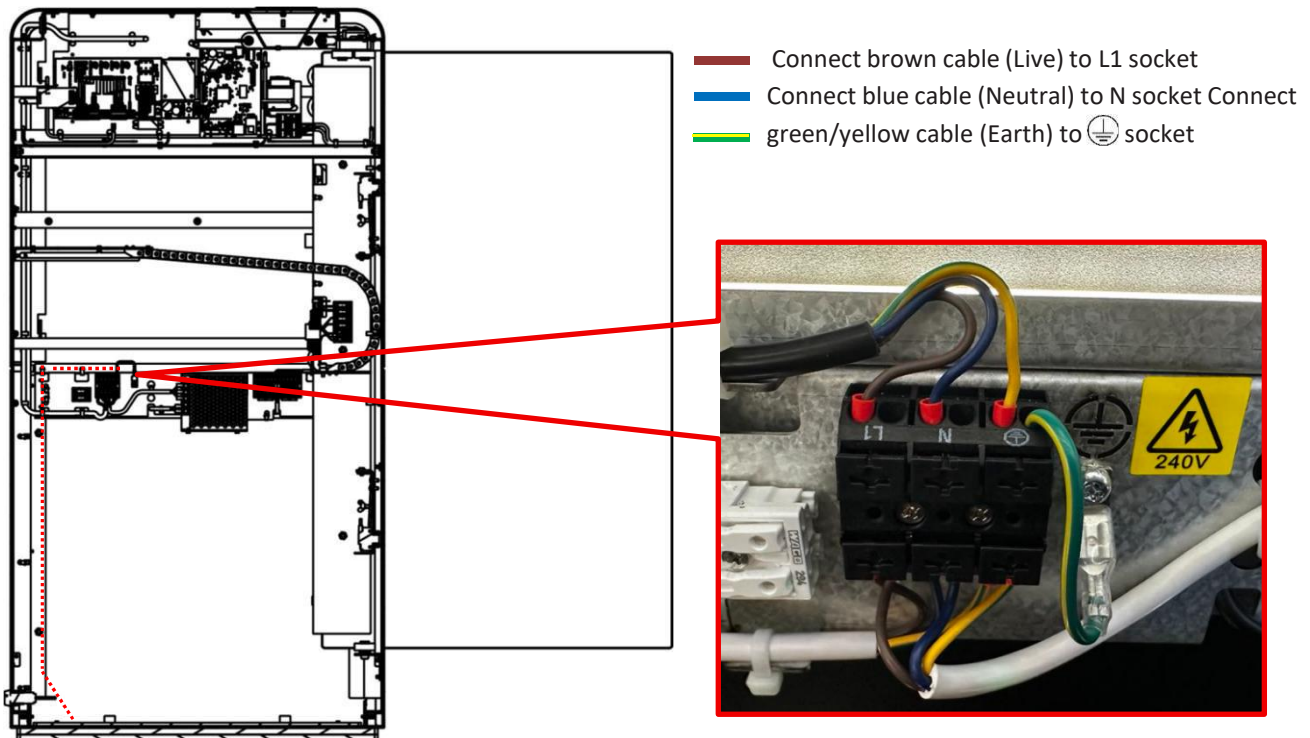

15. SigmaGate isolation switch installation

The isolation switch provides a dedicated means to disconnect power to the exit gate for servicing, maintenance, or emergency shutdown.

Requirements:

Switch type:

- 10A minimum grey isolator, *Clipsal IP56 Series 56SW110-GY* (or equivalent).

Labelling:

- Must be clearly labelled "EXIT GATE POWER."

Ingress protection:

- Minimum IP56 rating for moisture and dust protection.

Circuit connection:

- Install a dedicated UPS circuit if necessary.
- Ensure total gate load (120 W max per gate) does not overload the circuit.

Installation notes

- All wiring must comply with AS/NZS 3000 electrical standards.
- Coordinate location and connection with the electrical contractor responsible for gate power routing.
- Verify isolator function as part of commissioning and handover testing.

16. Connection of GateCOM/Crossover cable/Saloon Cable through MPB junction box

- Connect ground to socket marked 1.
- Connect signal to socket marked 2.
- Route the cable to the other gate via the floor chase and terminate at the opposing gates junction box using the same method
- This completes the loop between the main PCB boards and can now be tested using the test button on the main PCB board
- **Check operation of GateCOM** before connecting data cables using test switch on the SigmaGate main PCB

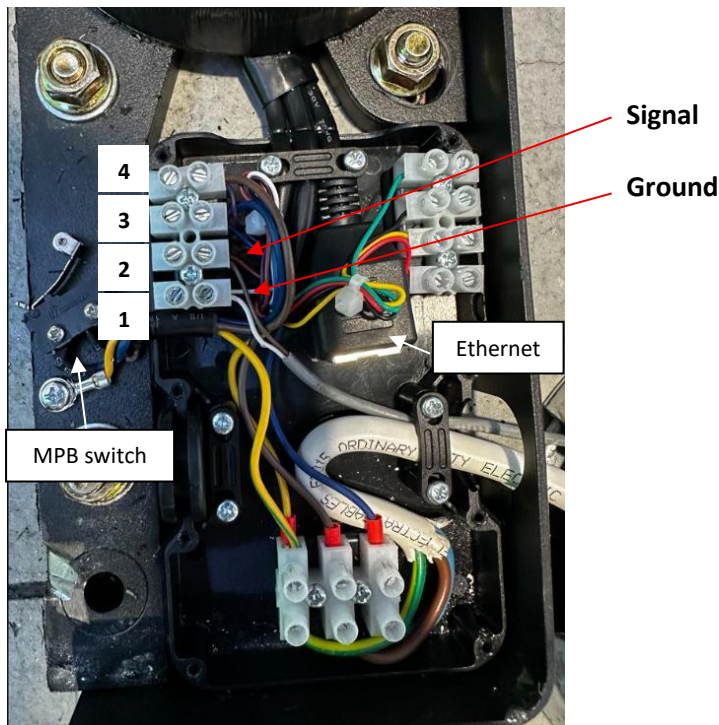

Example of the full connection that the above process creates.

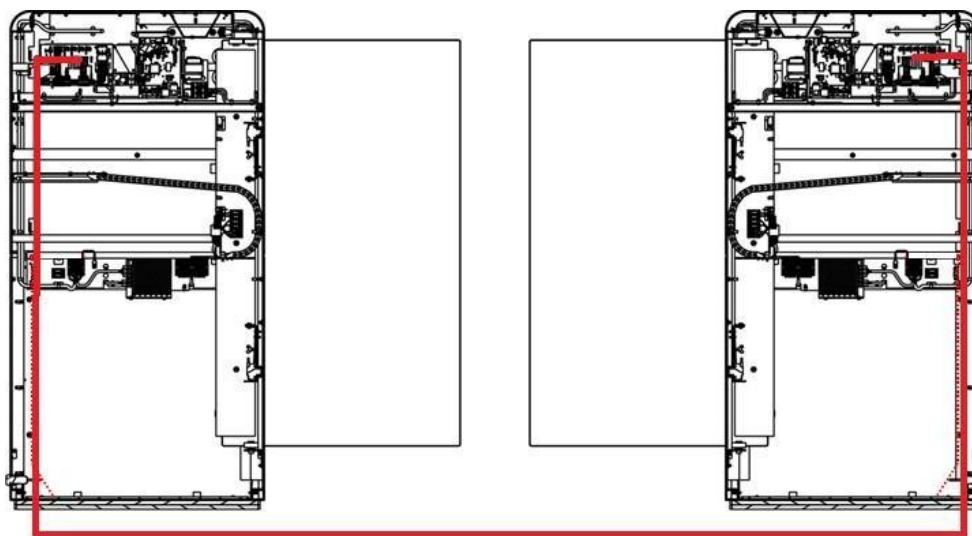

17. Install split junction box cover

After wiring in all cables in the gates junction box you will have to replace the junction box cover with another cover who isolates the high and voltage cables in the junction box. This will have to be done on both sides.



18. Connection of Ethernet

The SigmaGate is equipped with a ScanMaster on the right-hand side gate (right from when exiting through the gate) and is intended to be connected to the store POS system an Ethernet cable (cat7 or higher are recommended) needs to be connected to the ScanMaster 2.0.

Note: It is highly recommended to install an external isolation switch to the high voltage power supply.

Cable terminations

Radford recommends either of the two following options:

Data cable is to be run from comms cabinet directly to the ScanMaster board with no breaks in the cable. Tech must bypass the data cable in the MPB bracket at the base of the gate. (see green dotted line below of how to rout the cable inside the gate)

Or

The data cable is connected to the RJ45 connector in the base plate (data cable with suitable protective sleeve or shroud). An additional cable must go from the other RJ45 connector in the base plate up to the ScanMaster. (See the green dotted line below which is the data cable routing path)

Disclaimer: The ultimate responsibility of the cable terminations of this equipment lies with the licensed installers.

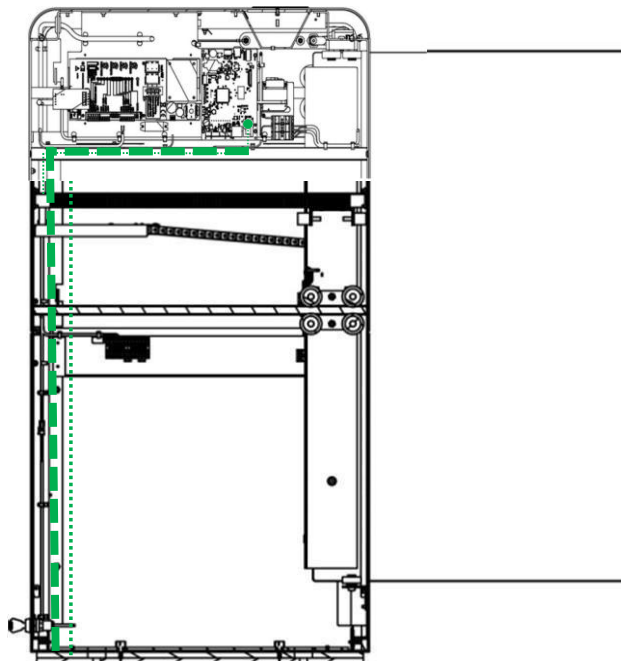

19. Adjustment of Gate PEC

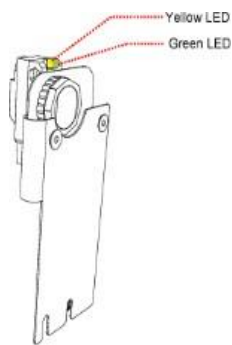
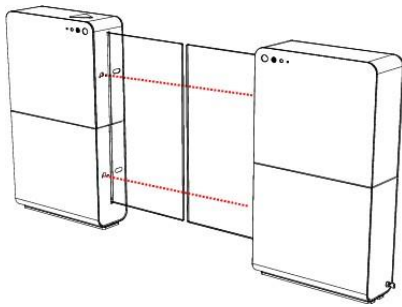

Make sure the two photoelectric cells (PEC) are pointing at the center of the reflectors on the other gate.

Adjust by using 2,5mm Allen keys through holes next to PEC sensor on outside of gate.

Step 1

Turn Allen key all the way LEFT until yellow connection light turns off.

Step2

Turn Allen key all the way RIGHT until yellow connection light turns off, counting the amount of turns in between.

Step3

Wind Allen key back to mid position.

EG. If it takes 6 full turns from left position to right position, then turn back 3 full turns.

IMPORTANT NOTE:

This must be done in both vertical and horizontal directions

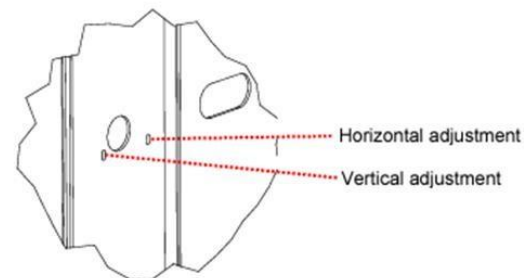
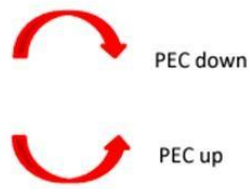
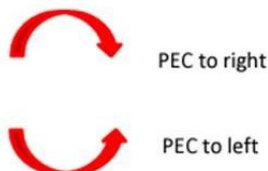

Note: The gates come with different PEC sensors installed. Some are yellow and others green. Each sensor has a sensitivity dial on the back. Please ensure the dial is adjusted as follows:

- **Green PEC sensors:** Turn the dial fully clockwise to maximum sensitivity.
- **Yellow PEC sensors:** Set the dial to 50% sensitivity.



PEC sensor sensitivity dial



20. Customer Facing Safety Radar installation

1. Find the SigmaGates and make sure you are installing the Safety radars as they are about to walk through the gates.



2. Open SigmaGates using the remote and then turn gate off by turning the key to the vertical position (only turns off the power to the motor) or cut the power to the gate.



3. Unlock Service hatch by using a flat head screwdriver to turn the lock into the vertical position.



4. Lift service hatch up and away from the SigmaGate.

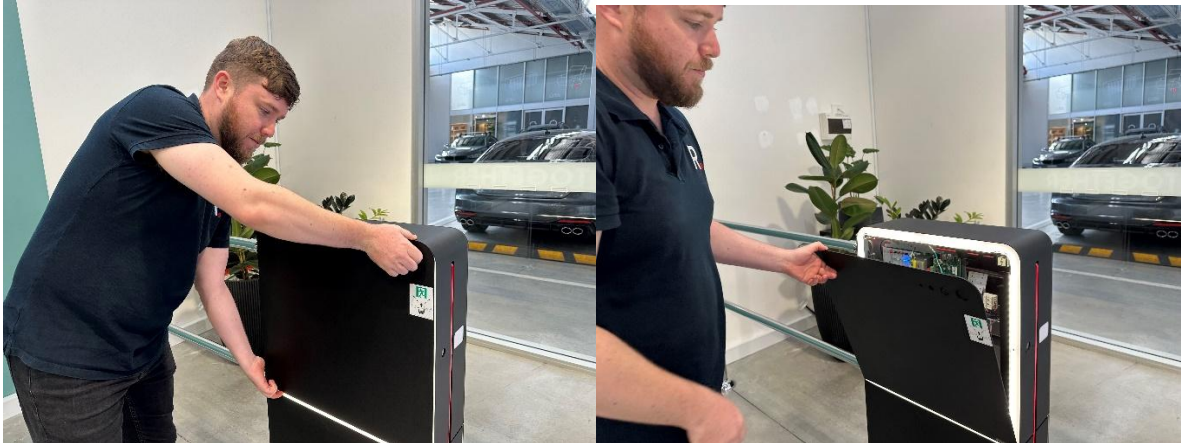

5. Disconnect the earth cable from service hatch.



6. Disconnect the power to the gate sides.

Note: Make sure you do not restart the ScanMaster or powering off and on the gate to often since this can damage the SD-card. Recommendation is to power off gates, leave them like that and power on again once installation is done and avoid restarting the ScanMaster using the button on the PCB.

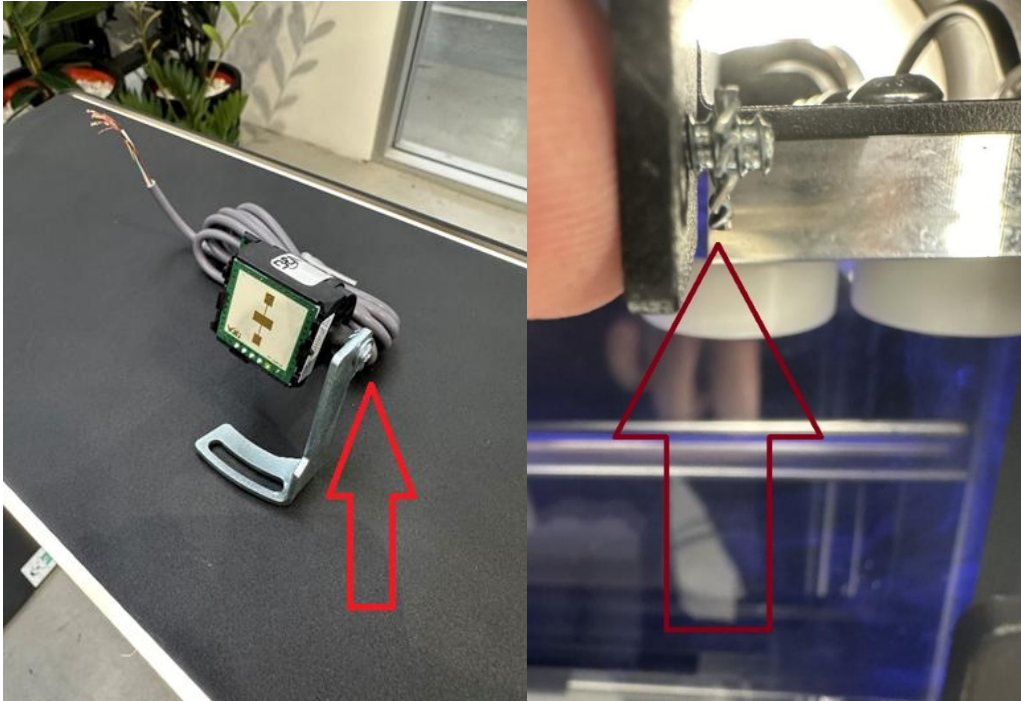

7. Remove the screw from the bracket and discard the bracket if supplied. Use the bracket screw and washer to mount the customer facing radar to in the corner of the SigmaGate with the washer between the mounting plate and radar **THIS IS IMPORTANT!** so that the radar does not slip after install.
8. It is also particularly important when tightening the screw that the radar is tilting downwards. This is to make sure that the radar picks up all customers.



Safety radar wiring

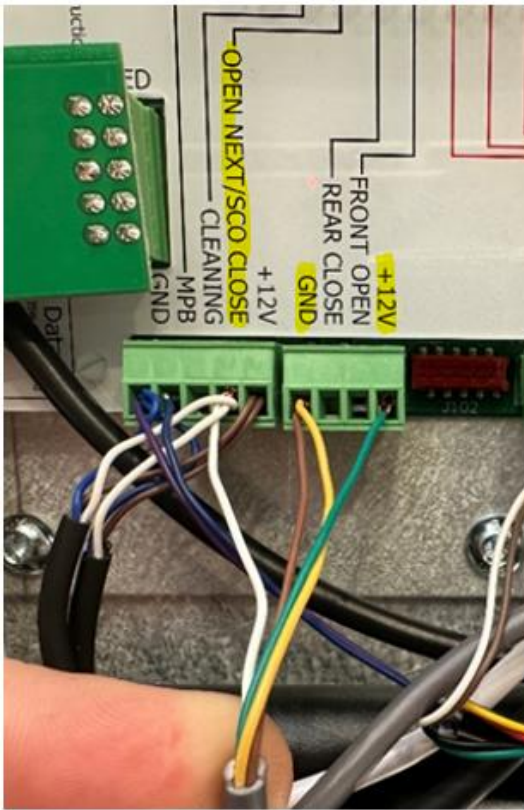

+12v = Green wire

GND = Brown and Yellow wires

OPEN NEXT/SXO CLOSE = White wire

9. Adjust the potentiometer on the side of the radar as shown in the image below left to set the detection range. The radars red LED will illuminate when a customer is detected as shown in the image below right.

Maximum sensitivity: Potentiometer turned all the way clockwise.

Minimum sensitivity: Potentiometer turned all way anticlockwise.

Note: The tuning of the radar will be the same no matter if it got the dial on the right or left side of the radar.

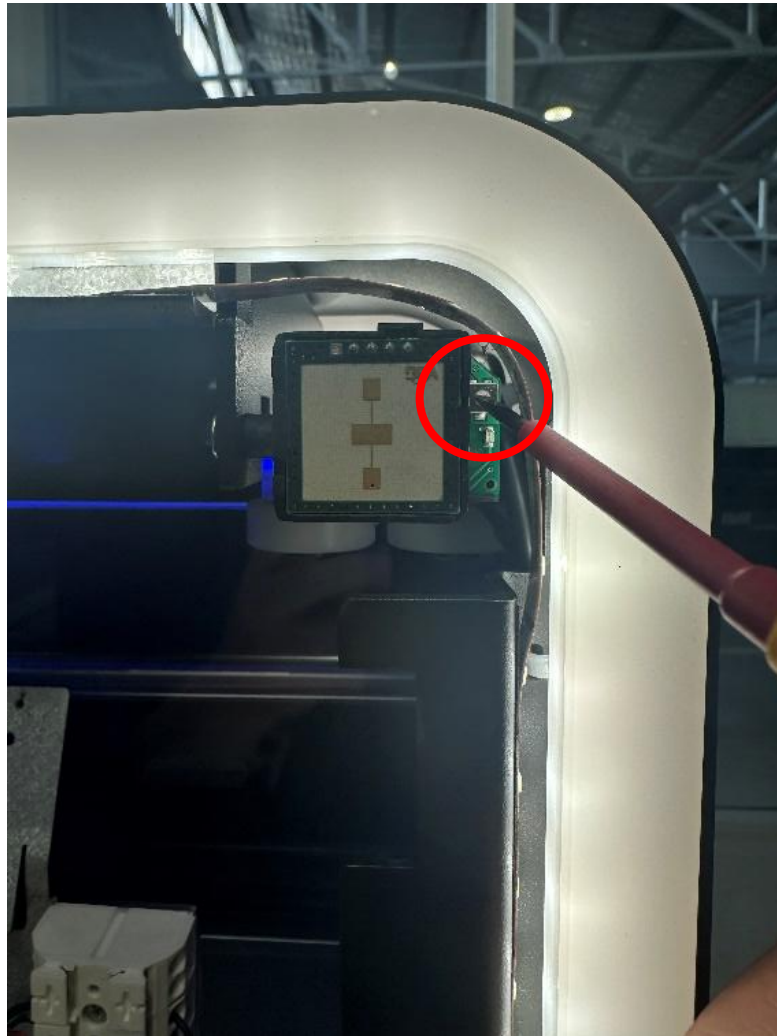

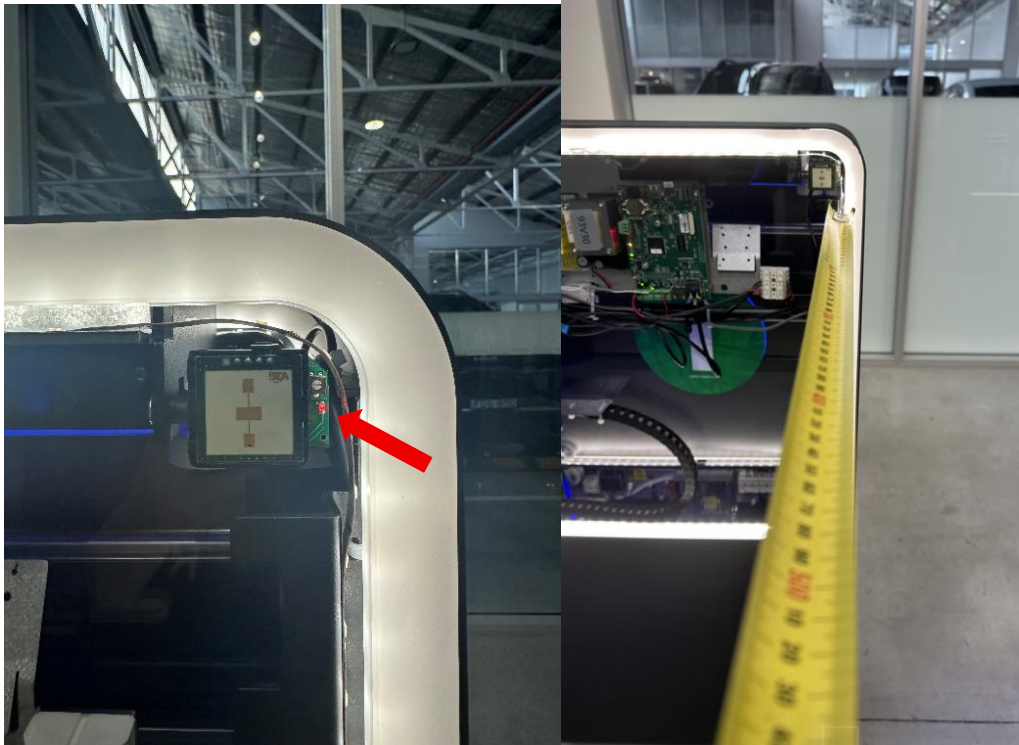

10. Set radar distance to **600mm** with the cover on using a measuring tape and the red LED indicator light to show that it is detecting customers.

Note: When evaluating the distance with the cover on the trigger distance will slightly decrease. Also make sure there is no checkouts opposite to the gate that might trigger the safety radars to trigger while closing.

11. Close up the SigmaGate by doing the inverse of the opening procedure.
 - Place service hatch on gate
 - Connect earth cable
 - Close service hatch
 - Close lock by using a flat head screwdriver turning it into the horizontal position
 - Power up the gate again.
 - Return gate functionality by using the remote.

21. Adjustment of Glass Door

If the glass doors need to be adjusted an adjustment screw (Allen screw M3) located on the lower section of the glass door can be adjusted (marked in red).

Before adjustment, three M6 nuts need to be loosened (marked in green).

Note: After adjustment, make sure to tighten the M6 nuts.

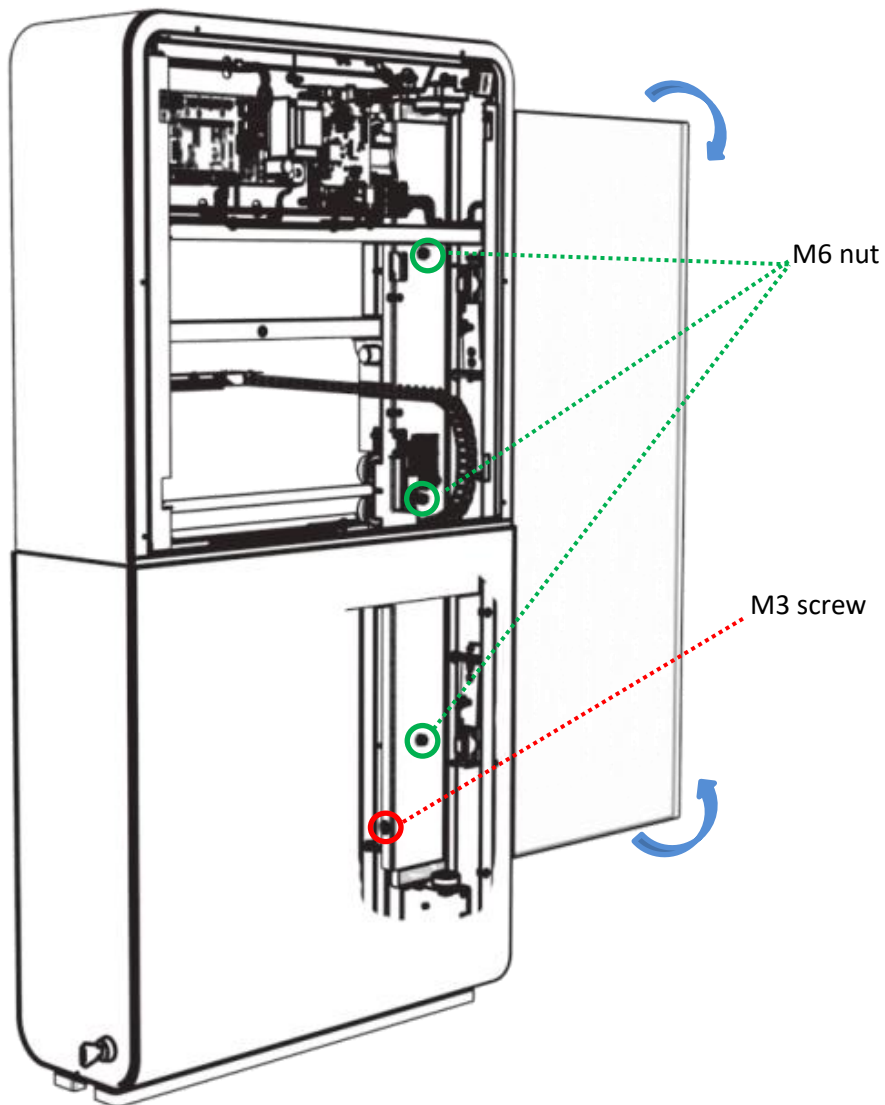

22. Configuration of ScanMaster 2.0

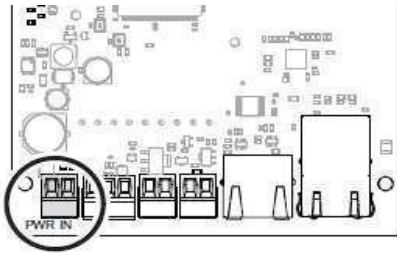

- 1 Disconnect the 12V power supply cable to cut the power.

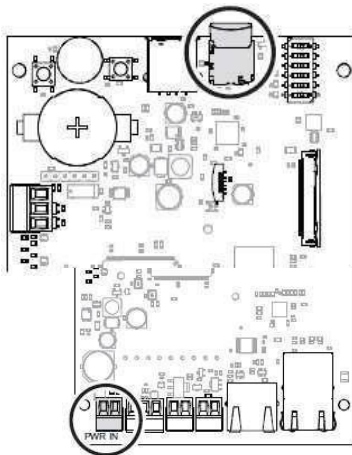

- 2 Put the Micro SD card for specific gate to the ScanMaster board.
Note: PLEASE CHECK THAT THE SDCARD IS THE CORRECT CARD FOR THE CORRECT GATE. Check against floor plan and IT Tracker.

- 3 Connect the 12V power supply cable.



- 4 The ScanMaster board will initialize over approximately 90 seconds. Once complete, the LED indicators should display as follows:
 - LED 1 - Blinking green: Indicates normal operation.
 - LED 5 - Single orange blink: Triggers once when a POS message is received
 - LED 10 - Solid red: Indicates fault or error state.

23. DIP-switch settings ScanMaster

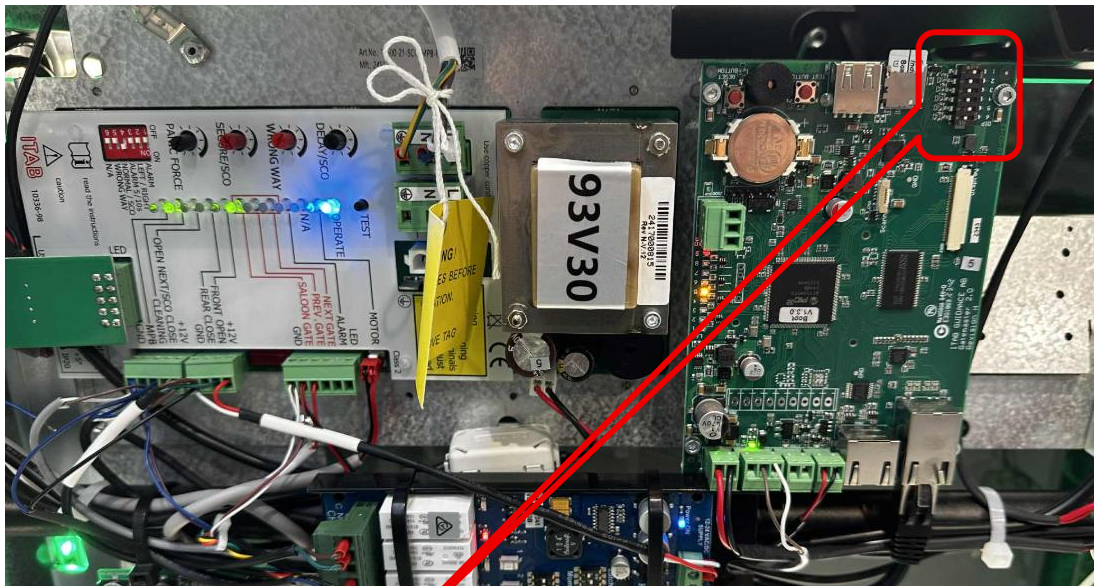

ScanMaster DIP-switches

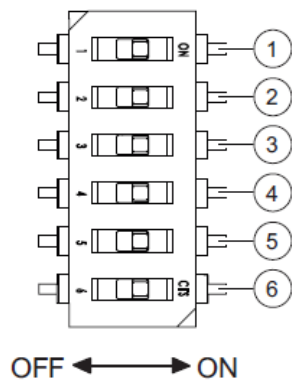

1. Buzzer on/off = **Right (ON)**
2. Ethernet required = **Right (ON)**
3. Service mode = **Left (OFF)**
4. Service IP (192.168.20.200) = **Left (OFF)**
5. GateCOM required = **Right (ON)**
6. Display on/off = **Left (OFF)**

24. Master & Slave Dip Switch Settings

The purpose of the Master and Slave function is to make it easier to set the timer functions on the main board. In a saloon configuration the right-hand gate (in the direction of the customers' travel) is ALWAYS the Master.



LEFT GATE

1. ALARM = Right (ON)
2. LEFT/RIGHT = Left (OFF)
3. ALARM 5/10s = Left (OFF)
4. NORMAL/SCO = Right (ON)
5. WRONG WAY = Left (OFF)



RIGHT GATE

1. ALARM = Right (ON)
2. LEFT/RIGHT = Right (ON)
3. ALARM 5/10s = Left (OFF)
4. NORMAL/SCO = Right (ON)
5. WRONG WAY = Left (OFF)

25. Master & Slave Potentiometer settings

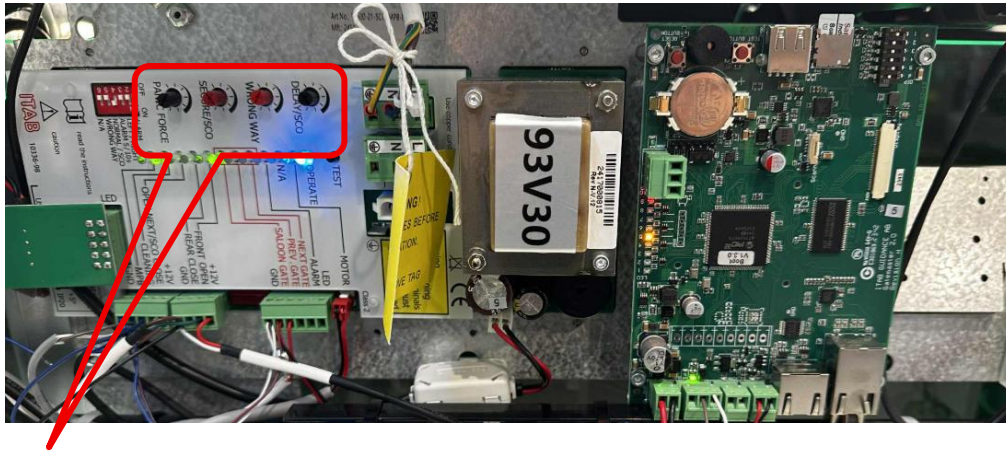

1.



DELAY: This sets the amount of time the gates will stay open after a customer has left through the gates and broken the PEC sensor beam. Range 0-8 seconds.

Note: This timer will override the securetimer.

2.



WRONG WAY: This timer is used to detect movement through the gates in the wrong direction. Please set to full right to avoid picking up a customer's swinging arm. Range 0.1-2 seconds

3.



SECURE: This timer will keep the gates open until the customer has passed through the gates. Once the customers pass through the gates this timer gets override by the DELAY timer. Range 0-30 seconds

4.



PANIC FORCE: This dial sets the force required to slide the glass arm back into the body of the SigmaGate

LEFT GATE (left gate when exiting through the gate)

1. Set DELAY, WRONG WAY, SECURE on the left-hand gate to maximum/clockwise. (100%)
2. Set PANIC FORCE to minimum/anticlockwise (0%)

RIGHT GATE (right gate when exiting through the gate)

1. Set DELAY to halfway. (50%) (4 seconds)
2. Set WRONG WAY to maximum/ fully clockwise. (100%) (2 Seconds)
3. Set SECURE to halfway. (50%) (15 Seconds)
4. Set PANIC FORCE to minimum/ fully anticlockwise. (0%)

Hint = turn all the way left (0%) then all the way right (100%) to work out where 50% is.

Note: For the Master and Slave function to be operational the gate configuration must be connected with GateCOM crossover cable (Saloon) to the opposing gate *See page 19.

26. Check the gate timing using the ScanMaster board

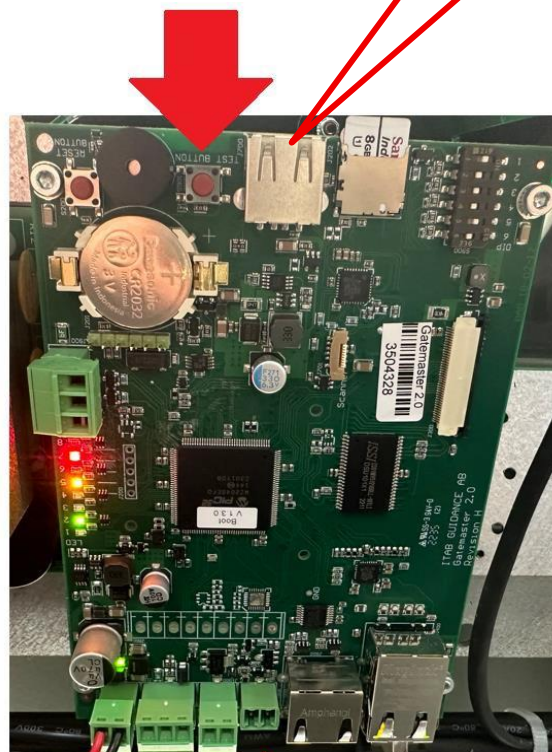
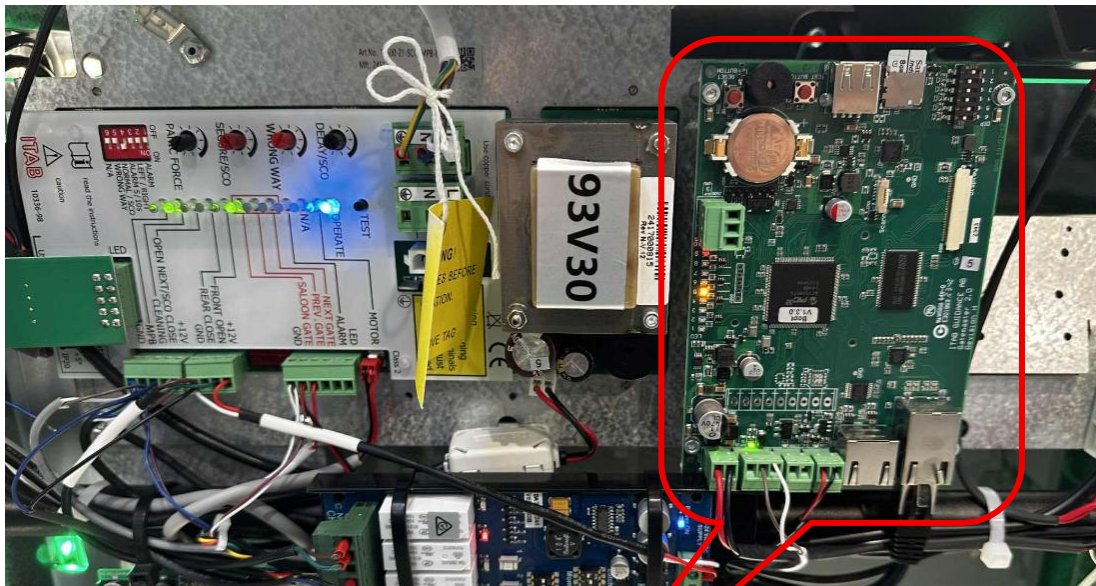

Use the test button on the ScanMaster to trigger the gate. This will send an open gate signal to help check the timing of the gate. Please note that this will only trigger the gate and start the Secure timer until the PEC sensor is broken.

Hint: Use your hand to break the PEC beam to start the DELAY timer.

27. Remote Installation (Gen 3 Remotes)

The following instructions will explain how to install a remote receiver inside a SigmaGate and how to set up the remote's functions if there is only one gate in the store controlled by the remote controls.

Note: The Generation 3 receiver does not include wiring. The installer will need to supply the necessary cables. To connect the receiver to the gate, you will need three 50 cm long 2-core wire cables.

Button 1 - will be programmed to activate 'Auto Close' on SCO Gate.





Button 2 - will not be used.

Button 3 – will not be used.

Button 4 –will be programmed to activate 'Cleaning Mode (permanent open mode)'.

Note: The remote-control receiver must be installed on the same gate side as the ScanMaster or the latched/cleaning signal will not be detected by the ScanMaster.

27.1. Wire the Receiver to SigmaGate Control Board

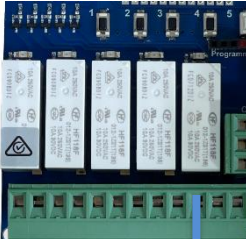
Receiver	SigmaGate Control Board (SCO Gate)
<p>Supply +</p> 	<p>12V</p>
<p>Supply -</p> 	<p>Ground</p>
<p>Ch1 NO</p> 	<p>Front Open</p>
<p>Ch1 C</p> 	<p>Ground</p>
<p>Ch4 NO</p> 	<p>Cleaning</p>
<p>Ch4 C</p> 	<p>Ground</p>

Connecting Power

1. Open the SigmaGate panel.
2. Connect **Supply +** to **12v** on the Sigma control board.
3. Connect **Supply -** to **Ground** on the Sigma control board.

Relay 1 (Auto-Close)

1. Connect **Ch1 NO** to **Front Open** on the Sigma control board.
2. Connect **Ch1 C** to **Ground** on the Sigma control board.

*Please note if the store, for example, has 3 pairs of gates and 3 receivers. Use relay 1 on the first pair. Relay 2 on the second pair. Relay 3 on the third pair.

Relay 4 (Latched/Cleaning Mode)

1. Connect **Ch4 NO** to **Cleaning** on the Sigma control board.
2. Connect **Ch4 C** to **Ground** on the Sigma control board.

*Please note that at a 3 gate store this will only be required for one receiver, otherwise all gates will be held open at the same time.

27.2. Mount the receiver

Note: The remote-control receiver must be installed on the same gate side as the ScanMaster or the latched/cleaning signal will not be detected by the ScanMaster.

Fit the receiver into the plastic bracket. Fit it into the trace.

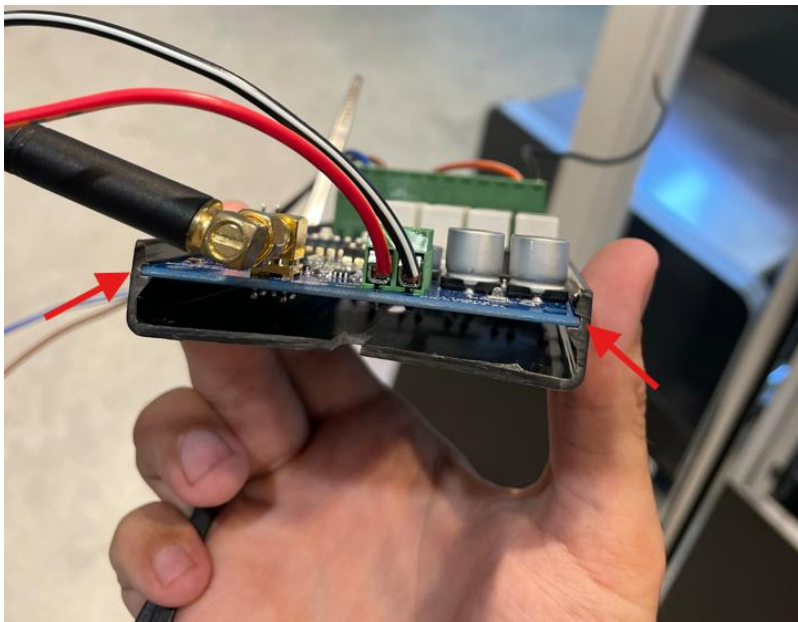

Remove cables from rail (creates extra space, otherwise the receiver can hit the cover when putting it back).

*Please note, if you don't have the plastic bracket, don't remove the cables. The cables will protect getting metal against metal.

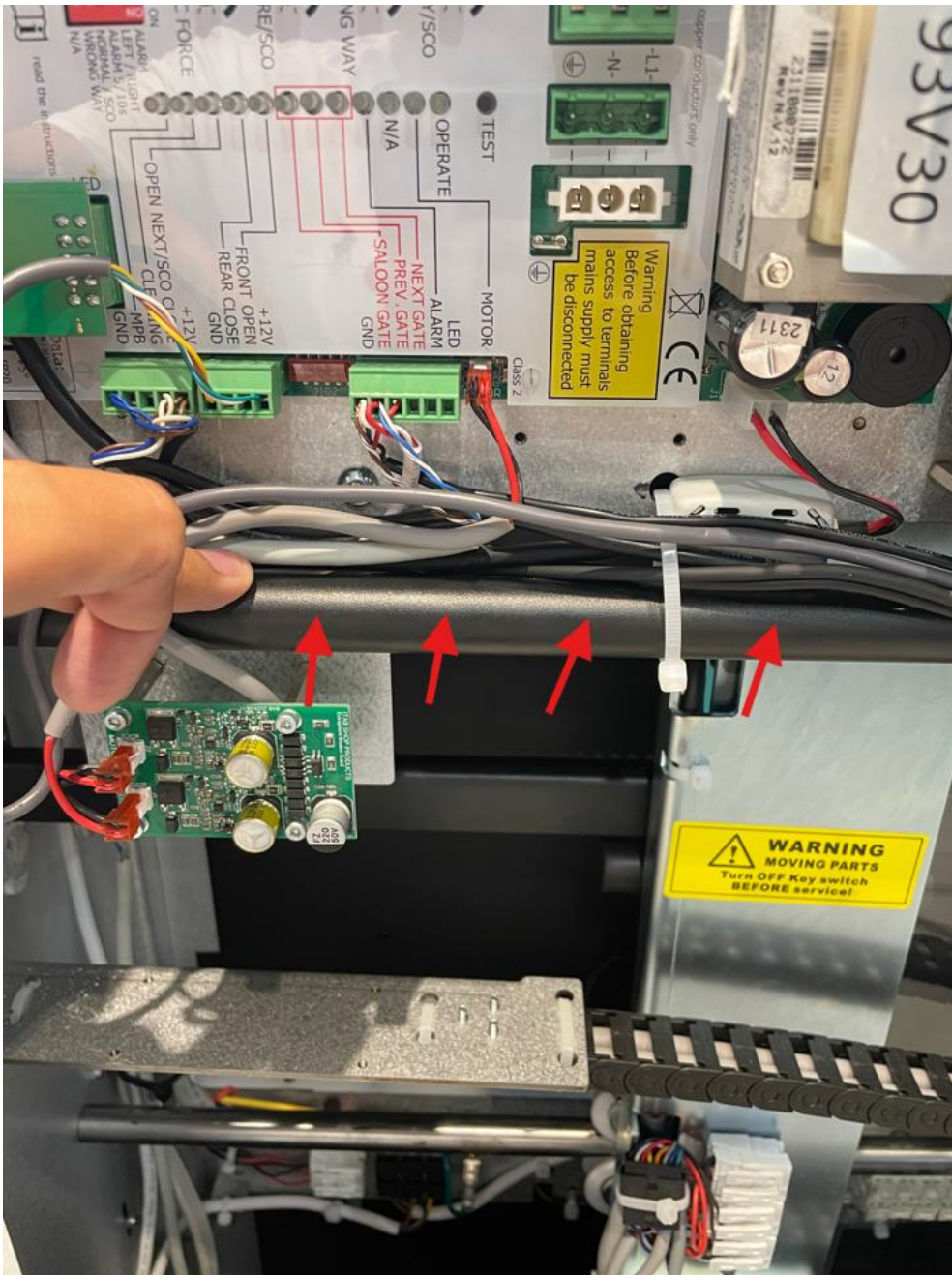

Let the bottom left corner "rest" on the screw to make it more stable (see second picture). Secure the receiver and cables with two cable ties (red arrows).

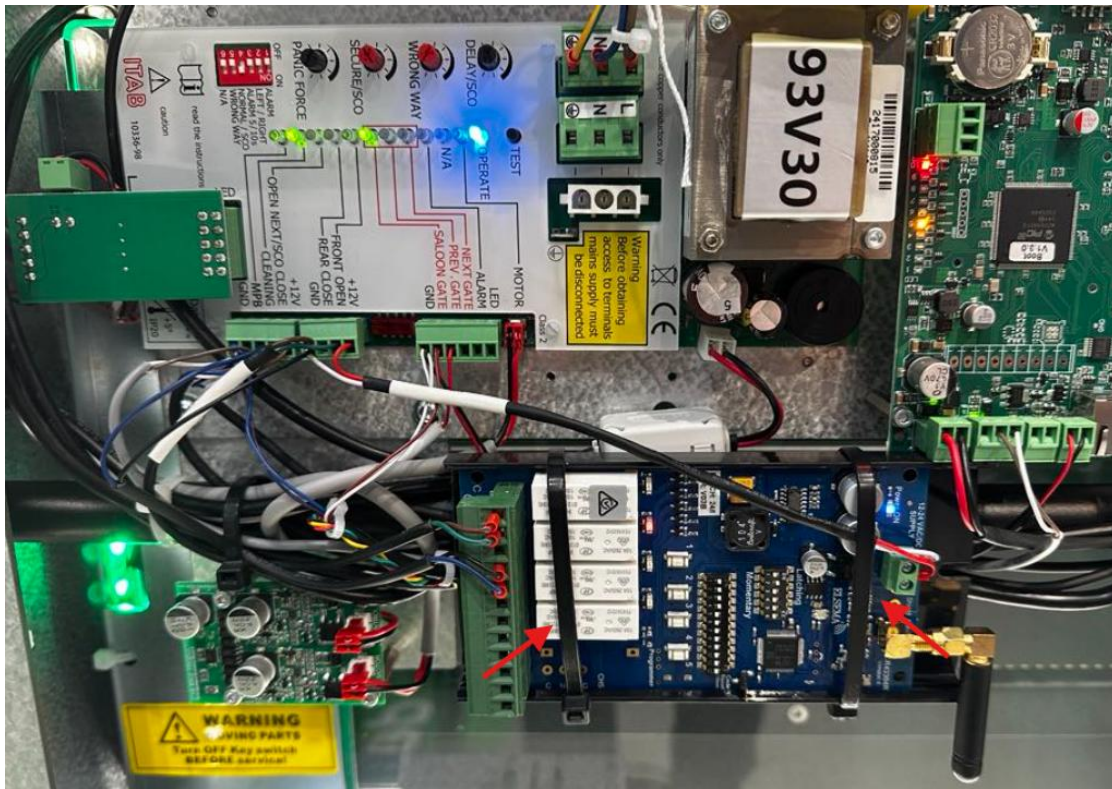

- The table below explains Dip switch 11 and 12. The first receiver should always have Off/Off. If you the store has two receivers. The first should have Off/Off and the second should have On/Off. Follow the table for all the different set ups.

	Receivers Dip Switch 11	Receiver Dip Switch 12
Receiver 1	Off	Off
Receiver 2	On	Off
Receiver 3	Off	On
Receiver 4	On	On

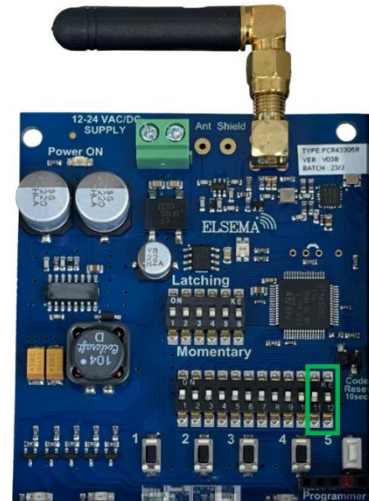

- Set Dip switches 1-10 in the remote exactly the same as the receiver. Dip switch 11 and 12 should always be Off/Off.



- Lastly, insert the battery and test the functions.



28. Remote monitoring cable

The purpose of the remote monitoring cable is to help the Sesame 2 software to monitor the use of the remote control for statistical purposes.

Please link two signal cables between cleaning and GND on the Gate control board and the middle port and the right port on the 3-pin connector on the ScanMaster 2.0 control board as shown below.

Note: The remote-control receiver must be installed on the same gate side as the ScanMaster or the latched/cleaning signal will not be detected by the ScanMaster.

Note: The Generation 3 receiver does not include wiring. The installer will need to supply the necessary cables.

To connect the scanmaster DIN port to the Gate control board, you will need one 50 cm long 2-core wire cables.

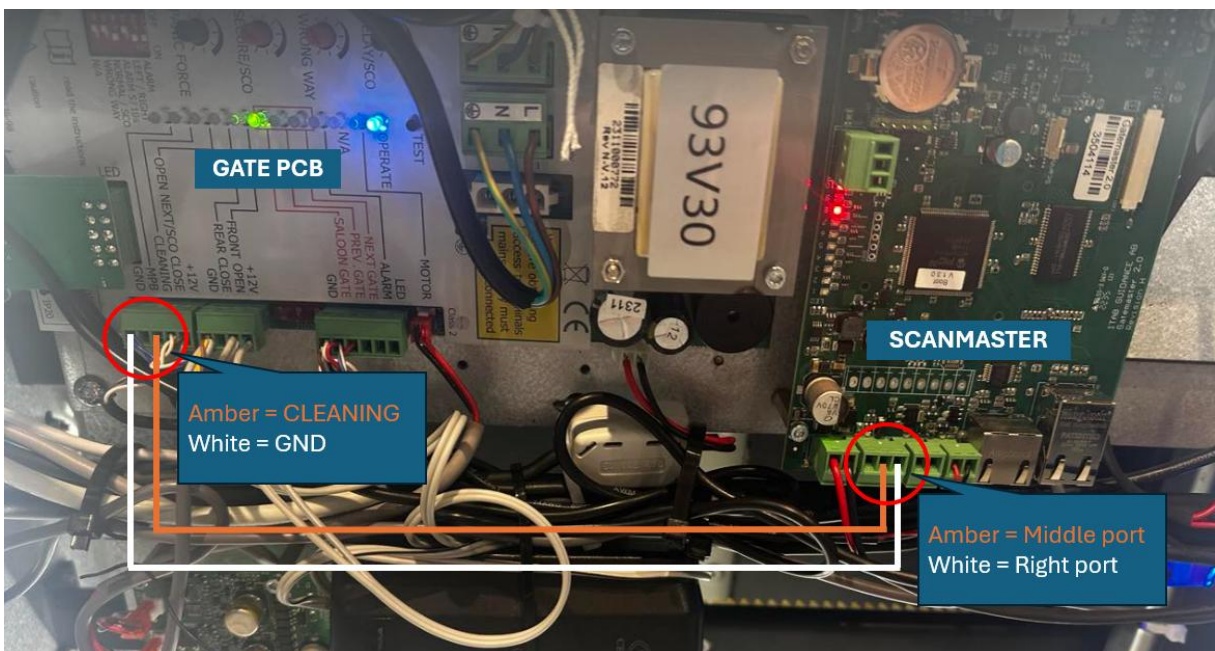

After connecting the signal cables between the ScanMaster and the Gate control board you need to verify that the ScanMaster board is picking up the latched/cleaning signal from the receiver/Gate control board. To do that you will first have to activate the latched/cleaning mode using one of the remotes. (Make sure the green LED light of the cleaning port is solid green on the GATE CONTROL BOARD. That means the latched/cleaning signal is active.

To know if the ScanMaster is picking up this signal, check the small LED above the middle port connector where the cable from the cleaning port is going into.

The LED should be solid green when latched/cleaning mode is activated and off when latched/cleaning mode is deactivated.

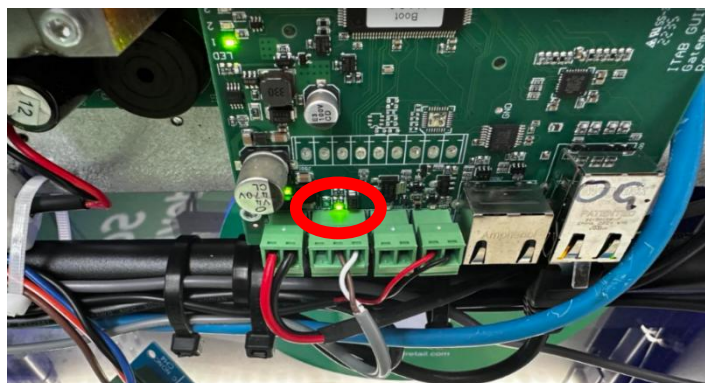

29. Commissioning sign-off checklist

Coles SigmaGate & Sesame 2 installation checklist & sign off document			
Complete the following check list when installation is complete:	✓	✗	Manual
	Yes	No	Check
Site manager to check that gates are fully operational by ticking the boxes and signing below:	(Ref. item #)		
Pictures of the cables coming through the brackets measured at 1918mm.			Page 11
Picture of 6 Chemset threaded rods (m10) through the bracket.			Page 15
Picture of Chemset filled bolt holes in gate brackets.			Page 15
Picture of earth, power and neutral connected to terminal in middle of gate and in MPB bracket.			Page 16/17
Ensure the isolation switch is installed according to the instructions and that it cuts power to the gate when turned off.			Page 18
Pictures of 2core cross over cable connected to gate terminal in middle of gate and then connected to GND and saloon on gate control board with saloon LED illuminated.			Page 19
Picture of Ethernet connection into ScanMaster on master gate (right when you exit through the gate).			Page 21
Picture of gate PEC sensors are aligned. picture of both lights on (4 sensors per gate set) (2.5mm Allen key).			Page 22
Video showing the customer facing radars being triggered as the person approaches the gate from a distance of 600 mm.			Page 23
Picture of ScanMaster SD card installed into ScanMaster.			Page 31
Picture of ScanMaster DIP-switch settings.			Page 32
Picture of dipswitch settings on gate control board.			Page 33
Video of gates closing behind customers after 4 seconds.			Page 35
Video of gates being open when triggered for 15 seconds.			Page 35
Provide a video showing the gate activating when the test button on the Gatemaster is pressed.			Page 35
Video showing button 1 triggering auto-close and button 4 triggering latched/cleaning mode on the remotes.			Page 36
If there are additional gates in the zone, capture a video showing button 2 and 3 triggering auto close.			Page 38
Picture of remote monitoring cable connected to the gate control board and with the remote-control receiver connected to the same gate control board. (For all gates if multiple)			Page 43
Video of the small green LED light of the ScanMaster being solid green while the remote control triggered the gate to latched/cleaning mode. (For all gates if multiple)			Page 43
Picture of gate body clear of debris (no excess cables, no cable ties etc.).			N/A
Fluke test results.			N/A
Gates are to be left keyed off and remotes are to be handed to the store manager and declaration signed.			N/A
Ensure all 4 PEC sensor glasses are cleaned on all installed gates post installation.			N/A
Ensure there is no dirt or fingerprints on the ceiling mounted sensors post installation.			N/A
Add gate serial number. Gate 1: _____ Gate 2: _____			N/A
Follow up work required:			
Are you satisfied that the finished works are compliant , and the layout is suitable to perform its intended operations?			N/A
Are there groundwork fixings follow up required?			N/A
Are there any screws or rubber/plastic bungs needing replacing ?			N/A
Are there any covers needing replacement ?			N/A
Are there any keys needed to be supplied to the store?			N/A
Is there any equipment left behind for Coles perusal (if yes please was the store manager notified of location)?			N/A

30. Store manager declaration

Coles sign-off document	
Store name:	
Store address:	
Store number:	
Store manager's name:	
Store manager's signature:	
Date:	
Contractor company name:	
Technicians' name:	
Technicians' signature:	
Date:	
Please make notes of any follow-up work required below	

31. Troubleshooting Schedule

Please read through the following steps:

Gates do not open:

- Check that there is power to the gate.
- Check the motor key switch is turned ON.
- Check if the gates are being held open on the remote controls.
- Check that the data cable is plugged into the ScanMaster 2.0
- Check the connections of GateCOM cross over cable.

Gates do not close:

- Check that the motor key switch is turned ON.
- Check that PERMANENTLY OPEN MODE is not activated by checking for illuminated LED on main PCB
- Check that the photoelectric cells are pointing directly at the corresponding reflector. See page 22 for adjustment of PEC.
- If the gates are equipped with Mechanical Panic Breakout, check that the gates are in normal position.
- If the problem is still not solved, switch off the mains power to the gate and turn it back on.

The gate alarm is activated:

- Check that the motor key switch is turned ON.
- Check that the photoelectric cells are pointing directly at the corresponding reflex. See page 22 for adjustment of PEC.

The gates do not behave as intended:

- Check the configuration of the gates concerning MASTER & SLAVE on page 33.
- Check that the photoelectric cells are pointing directly at the corresponding reflex.
- If problems continue, contact Radford Support.

For more installation & troubleshooting guides, please visit our knowledge base here:

<https://radfordretail.zendesk.com/hc/en-au>